

## Düşük Hızlı Yüksek Torklu Hidrolik Motorlar, W11 ve W61 Serileri

### Low Speed High Torque Hydraulic Motors, W11-W61 Series



#### W11 - W61 Serisi Orbit Hidrolik Motorlar / W11-W61 Series Orbit Hydraulic Motor

Oil Distributor	Series	Displacement cc/r [in <sup>3</sup> /r]	Max. Pressure MPa [PSI]	Speed Rpm	Max. Torque Nm [lbf-in]
Spool Valve	W11	50-400 [3.1-24.4]	14 [2030]	145-858	521 [4611]
	W21	50-500 [3.1-30.5]	17 [2465]	110-863	500 [4425]
	W31	100-400 [6.1-24.4]	16 [2320]	121-540	660 [5841]
	W41	245-800 [15.0-48.8]	15 [2175]	106-390	1380 [12214]
Disc Valve	W51	80-500 [4.9-30.5]	28 [4060]	142-856	860 [7612]
	W61	195-985 [11.9-60.1]	31 [4495]	155-865	1877 [16613]

#### Model Correspondance to Other Brands

WINMAN	Sauer Danfoss	Eaton Charlynn	Parker	M+S	SAM
W11	OMP	H Series	OMP	MP / MLHP	BG, BH
W21	OMR	S Series	TC; TB; TE; TH	MR / MLHR	BR, BS, AR
W31	OMH	--	--	--	--
W41	--	--	TF; TL; TG	MH / MLHH	--
W51	OMS	2000 Series	OMS	MS / MLHS	HR
W61	OMT;OMV	6000 Series	OMT	MT / MLHT; MV / MLHV	HT

## Düşük Hızlı Yüksek Torklu Hidrolik Motorlar, W21 Serisi

### Low Speed High Torque Hydraulic Motor, W21 Series

#### W21 Serisi Hidrolik Motor / W21 Series Hydraulic Motor



#### Özellikler / Specifications

Deplasman Displacement cm <sup>3</sup> /r [in <sup>3</sup> /r]		50 [3.1]	63 [3.8]	80 [4.9]	100 [6.1]	125 [7.6]	160 [9.8]	200 [12.2]	250 [15.3]	315 [19.2]	400 [24.4]	500 [30.5]
Akış Flow LPM [GPM]	Cont.	40 [9]	53 [12]	58 [13]	58 [13]	58 [13]	58 [13]	58 [13]	58 [13]	58 [13]	58 [13]	58 [13]
	Int.	46 [10]	58 [13]	68 [15]	68 [15]	68 [15]	68 [15]	68 [15]	68 [15]	68 [15]	68 [15]	68 [15]
Max. Hız Max. Speed (RPM)	Cont.	750	760	653	551	440	344	276	220	175	140	110
	Int.	863	832	766	646	516	404	323	258	205	162	128
Basınç Pressure ^Bar [ ^PSI]	Cont.	140 [2030]	140 [2030]	140 [2030]	140 [2030]	140 [2030]	140 [2030]	125 [1813]	110 [1595]	90 [1305]	90 [1305]	80 []
	Int.	170 [2465]	170 [2465]	170 [2465]	170 [2465]	170 [2465]	170 [2465]	150 [2175]	130 [1885]	110 [1595]	100 [1450]	90 [1305]
Tork Torque Nm [lbf-in]	Cont.	89 [788]	112 [991]	142 [1257]	178 [1575]	223 [1974]	285 [2522]	318 [2815]	350 [3098]	360 [3186]	418 [3700]	464 [4107]
	Int.	108 [956]	136 [1204]	172 [1522]	216 [1912]	270 [2390]	346 [3062]	382 [3381]	413 [3655]	400 [3540]	464 [4107]	500 [4425]

- Not:**
- Hidromotor aralıklı olarak pik basınçta çıkış de eridir. Hidromotor sürekli belirtilen basınçlarda çalışabilir.
  - Motorda yüksek basınç ve maksimum hız altında çalışma olmamalıdır.
  - Çalışma süresi pik basınçta normal sürenin %10'unu geçmemelidir.
  - Önerilen hidrolik ya ı, viskozite 37-73 cSt, temizlik ISO18/13 olmalıdır.
  - Maksimum çalışma sıcaklığı 80 °C'dir.
  - Maksimum çalışma basıncı %40 altında bir saat tam kapasite ile çalışması tavsiye edilir.
  - İzin verilen maksimum geri basıncı 100 bar, ancak önerilen geri basınç olmamalıdır. Sızıntı hattına 50 bar kapasiteli boru gerekmektedir.

- Note:**
- Intermittent means the entrance of the maximum pressure; continuous working pressure means the differential pressure.
  - Motor should not work under the highest pressure and the maximum speed.
  - The running time should not exceed 10% under intermittent working conditions.
  - Recommending N68 anti-wear hydraulic oil, viscosity 37-73cSt, cleanliness ISO18/13.
  - The Maximum working temperature is 80°E.
  - One hour running time under 40% of maximum working pressure is recommended before full capacity working.
  - The maximum allowable back pressure is 10MPa, but the recommended back pressure should not exceed 5MPa.a leaking pipes is needed when exceeding.

## Düşük Hızlı Yüksek Torklu Hidrolik Motorlar, W21 Serisi

### Low Speed High Torque Hydraulic Motor, W21 Series

#### Performans Bilgileri / Performance Data

Sürekli

Aralıklı

Continuous

Intermittent

		W21-50 50ml/r							
		$\Delta P$ (Mpa)							
		5	7	9	10	12	14	16	17,5
Flow (LPM)	5	35	45	60	66	78	89		
		95	85	75	74	70	45		
10		36	45	63	68	79	95	106	120
		185	175	165	162	150	130	110	85
15		35	49	65	75	88	100	110	120
		282	276	265	260	250	230	210	185
20		34	45	65	69	85	95	110	125
		375	374	365	360	345	330	308	275
25		34	45	60	69	80	98	109	125
		475	466	460	450	436	420	395	360
30		35	45	60	68	80	95	109	125
		575	570	561	552	541	531	500	465
35		32	42	59	66	80	93	107	
		665	663	655	654	635	623	598	
40		30	41	58	66	79	92	105	
		760	758	753	750	738	725	700	
45		29	40	58	65	78	90		
		855	855	850	845	835	814		

		W21-63 63ml/r							
		$\Delta P$ (Mpa)							
		5	7	9	10	12	14	16	17,5
Flow (LPM)	5	41	60	76	83	98	112		
		76	67	59	58	55	36		
10		45	61	77	85	101	118	132	150
		146	138	130	125	120	102	87	67
15		43	61	80	92	110	125	138	150
		222	218	209	202	190	160	145	130
20		43	57	82	87	105	120	129	152
		295	294	288	284	272	245	223	195
25		48	56	76	86	100	122	130	153
		375	368	363	355	312	328	255	205
30		44	56	74	85	100	120	136	157
		454	450	443	431	427	419	395	367
35		40	53	74	83	100	117	134	
		525	523	517	516	501	492	472	
40		37	52	73	82	98	115		
		600	598	594	592	583	572		
45		28	48	70	80	93			
		675	675	671	667	659			

		W21-80 80ml/r							
		$\Delta P$ (Mpa)							
		5	7	9	10	12	14	16	17,5
Flow (LPM)	10	56	78	98	107	130	148	170	180
		115	108	105	100	91	75	53	45
20		50	82	105	118	132	160	180	188
		238	235	226	223	208	195	173	162
30		48	75	96	115	130	150	178	190
		364	360	356	345	330	320	300	283
40		45	72	97	105	128	149	177	189
		487	482	475	472	460	446	420	409
50		42	70	90	98	125	147	171	187
		615	615	606	599	590	568	547	535
60		40	63	85	95	118	142	169	185
		740	724	720	715	705	688	668	657
70		36	58	82	90	112	139	165	179
		860	852	840	837	820	810	790	776
75		29	56	77	85	110	133	162	177
		925	915	910	899	886	870	855	837

		W21-100 100ml/r							
		$\Delta P$ (Mpa)							
		5	7	9	10	12	14	16	17,5
Flow (LPM)	10	73	99	123	139	160	183	210	223
		99	95	86	85	75	62	52	45
20		68	95	123	143	165	199	220	238
		199	195	187	182	175	163	150	138
30		65	95	120	140	165	194	220	240
		299	294	288	285	278	263	249	235
40		59	88	119	135	161	192	218	238
		400	398	387	385	380	366	350	336
50		55	85	118	125	157	185	217	235
		499	495	488	484	475	463	451	436
60		48	79	110	119	150	180	216	235
		599	595	587	585	579	568	550	536
70		43	70	100	112	142	170	200	229
		699	692	687	683	679	668	645	636
75		39	63	98	105	140	167	198	227
		748	740	737	735	720	715	695	686

		W21-125 125ml/r							
		$\Delta P$ (Mpa)							
		5	7	9	10	12	14	16	17,5
Flow (LPM)	10	90	122	160	175	205	237	259	270
		72	71	65	63	55	42	22	14
20		85	119	158	172	208	250	278	292
		155	152	150	145	138	122	109	90
30		42	108	158	165	206	242	277	291
		236	235	233	225	218	206	192	170
40		79	105	150	161	205	238	275	289
		315	312	309	307	302	298	273	254
50		75	95	145	158	196	238	265	285
		399	395	393	390	380	368	355	337
60		60	95	139	155	183	223	254	279
		475	475	470	468	463	450	428	416
70		60	83	125	150	178	212	252	262
		555	552	550	549	545	538	515	500
75		55	80	122	145	172	205	245	261
		595	593	590	585	582	577	552	537

		W21-160 160ml/r							
		$\Delta P$ (Mpa)							
		5	7	9	10	12	14	16	17,5
Flow (LPM)	10	115	160	205	220	262	300	340	362
		57	56	52	50	43	38	34	27
20		115	160	206	230	265	320	355	380
		119	115	110	108	102	95	84	76
30		105	158	202	220	261	305	344	378
		184	180	177	172	165	153	134	130
40		100	145	195	218	256	299	340	375
		247	245	238	236	230	217	199	185
50		92	142	188	209	250	295	336	366
		307	305	300	298	290	280	261	244
60		84	137	180	199	240	286	330	360
		369	367	365	361	355	342	334	304
70		65	120	165	180	223	282	320	350
		436	435	430	427	415	402	336	366
75		60	117	158	175	220	272	314	342
		465	462	459	456	447	432	415	395

## Düşük Hızlı Yüksek Torklu Hidrolik Motorlar, W21 Serisi

### Low Speed High Torque Hydraulic Motor, W21 Series

**W21-200 200ml/r**

		$\Delta P$ (Mpa)						
		5	7	9	10,5	12	14	17,5
Flow (LPM)	10	149	205	255	290	328	370	443
		50	48	45	43	40	30	23
20		140	202	250	323	330	411	448
		99	96	93	90	85	78	65
30		130	192	242	307	325	376	445
		150	148	140	136	131	122	105
40		125	186	233	305	314	390	436
		200	196	193	188	181	170	149
50		120	177	225	295	305	382	427
		250	247	242	238	231	218	192
60		110	166	220	285	292	373	419
		300	295	290	288	282	268	236
70		98	150	205	244	278	330	410
		350	348	342	338	330	318	282
75		85	141	199	235	268	323	400
		375	372	366	362	356	342	310

**W21-250 250ml/r**

		$\Delta P$ (Mpa)							
		3	5	7	8	10	11	14	17,5
Flow (LPM)	10	115	182	252	295	350	380	470	535
		40	39	38	35	32	30	23	16
20		110	178	252	295	352	385	470	548
		80	79	75	75	69	67	57	48
30		100	170	250	285	349	380	469	546
		120	119	116	115	110	106	95	80
40		90	159	232	269	330	366	460	530
		159	156	155	153	150	147	130	110
50		80	148	216	252	320	352	453	520
		200	198	195	194	162	160	152	147
60		75	130	200	235	305	340	433	505
		240	240	238	236	232	228	210	180
70		50	117	190	220	290	320	412	495
		280	278	278	275	270	267	250	215
75		42	105	180	210	280	310	405	486
		300	299	298	297	294	288	272	239

**W21-315 315ml/r**

		$\Delta P$ (Mpa)						
		3	5	6,5	8	9	13	13,5
Flow (LPM)	10	135	215	279	343	385	515	550
		32	28	26	25	24	23	22
20		135	216	288	350	380	508	552
		60	59	58	57	56	52	50
30		125	205	275	340	375	494	543
		93	91	90	89	88	80	79
40		115	195	266	335	366	485	526
		122	120	119	118	117	105	104
50		90	170	252	320	352	474	511
		153	152	151	148	146	137	132
60		80	160	230	305	334	457	492
		190	185	190	178	175	160	156
70		58	135	215	285	320	442	470
		222	220	216	212	205	190	180
75		55	125	205	269	308	426	469
		234	232	230	227	225	208	200

**W21-400 400ml/r**

		$\Delta P$ (Mpa)						
		3	5	6,5	8	9	13	13,5
Flow (LPM)	10	170	252	370	440	485	595	620
		24	23	22	20	19	17	16
20		170	281	365	436	480	590	615
		48	47	45	44	42	40	36
30		154	278	355	426	470	580	610
		72	70	68	66	63	60	59
40		144	273	350	410	466	576	606
		95	94	90	83	80	76	70
50		137	269	344	406	460	570	600
		121	119	116	112	108	101	95
60		135	265	330	390	445	555	670
		145	140	134	130	118	110	105
70		120	245	315	370	435	545	650
		170	169	165	160	154	150	145
75		115	235	300	350	425	525	630
		180	176	170	165	162	158	153

**W21-500 500ml/r**

		$\Delta P$ (Mpa)					
		3	5	6,5	8	9	13
Flow (LPM)	10	200	345	462	582	635	755
		29	27	26	24	22	20
20		199	340	455	575	625	745
		39	38	37	36	34	30
30		190	328	447	566	626	739
		59	58	57	56	54	50
40		188	319	437	556	616	729
		78	77	76	75	73	70
50		180	310	427	546	606	718
		97	96	95	95	93	90
60		175	300	416	532	597	702
		118	117	115	114	112	110
70		170	290	413	521	586	690
		138	137	135	133	131	130
75		160	278	402	511	575	678
		158	157	155	152	150	149

**Not:** Tüm testler hidrolik ya ve 50°C de yapılmıştır. Çalışma şartlarına göre de erler farklılık gösterebilir.

**Note:** All the data are tested at 50°C with N68 anti-wear hydraulic oil. Actual data may vary slightly from unit to unit in production.



**Düşük Hızlı Yüksek Torklu Hidrolik Motorlar, W21 Serisi**  
**Low Speed High Torque Hydraulic Motor, W21 Series**

**Montaj Flanşları / Mounting Flange**

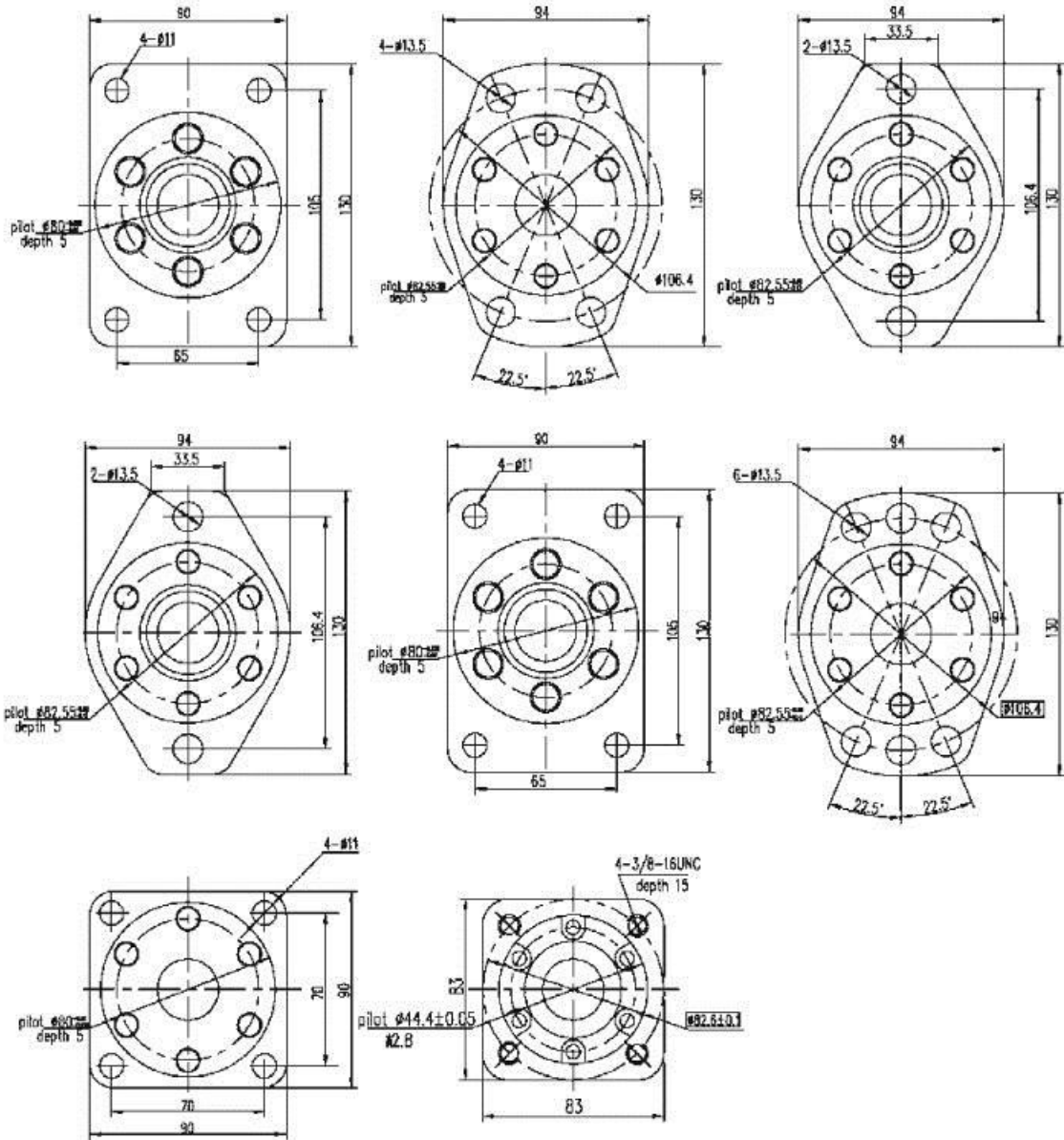

**Düşük Hızlı Yüksek Torklu Hidrolik Motorlar, W21 Serisi**  
**Low Speed High Torque Hydraulic Motor, W21 Series**

**Şaft / Shaft**

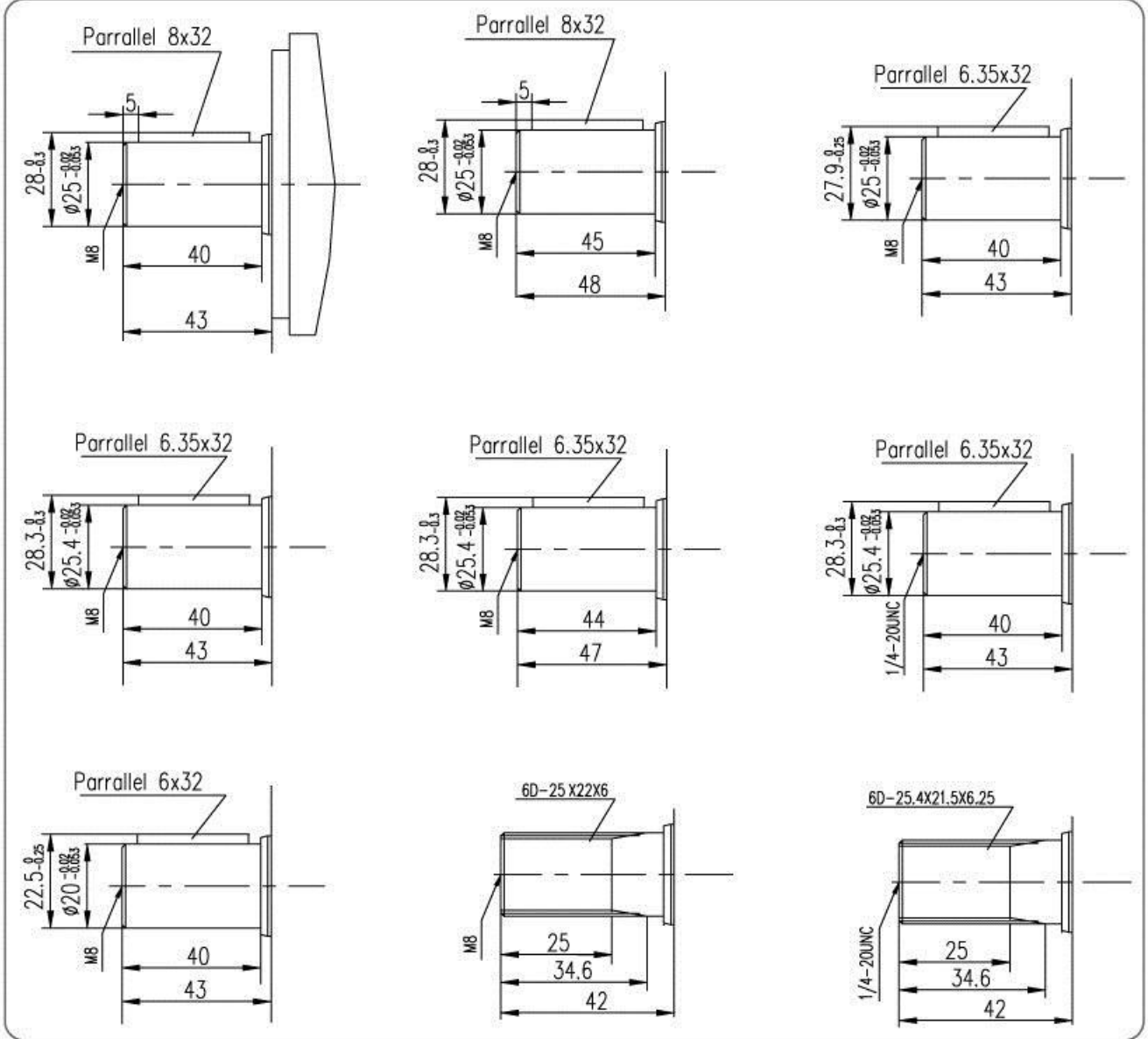

**Port**

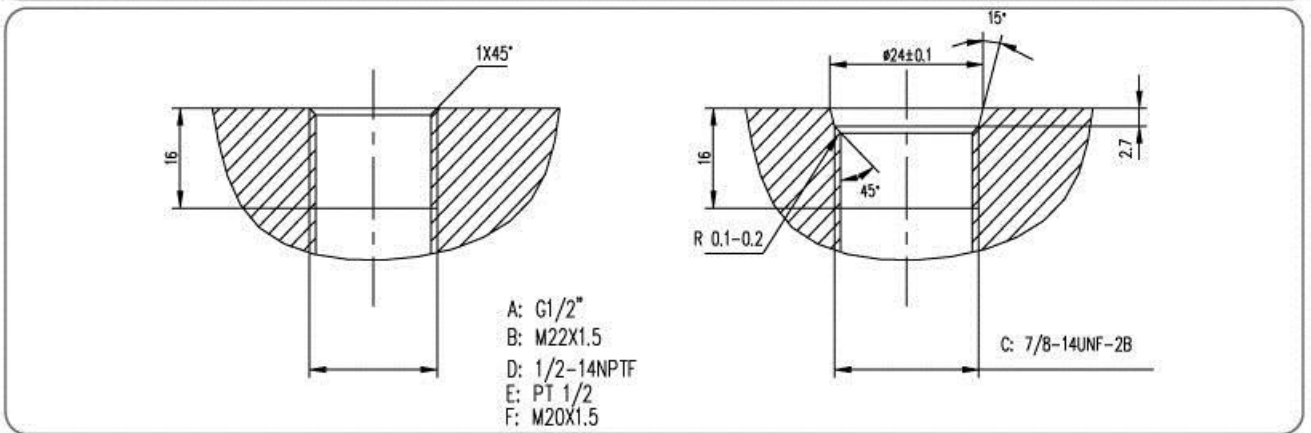

## Düşük Hızlı Yüksek Torklu Hidrolik Motorlar, W21 Serisi

### Low Speed High Torque Hydraulic Motor, W21 Series

#### Opsiyonel Ölçüler Kod Numaraları / Code Numbers for Optional Dimensions

Flange	Shaft	Oil Port	50	63	80	100	160	200	125	250	305	400
Rhomb-flange Pilot $\Phi$ 82.55	$\Phi$ 25.4,parallel key:6.35;shaft thread:1/4-20 UNC	G1/2"	21 - 00 10	-001 1	-001 2	-001 3	-001 4	-001 5	-001 a	-001 6	-001 7	-001 8
Rhomb-flange Pilot $\Phi$ 82.55	$\Phi$ 25.,parallel key:8;shaft thread:M8	G1/2"	21 - 00 20	-002 1	-002 2	-002 3	-002 4	-002 5	-002 a	-002 6	-002 7	-002 8
Square-flange Pilot $\Phi$ 80	$\Phi$ 25.,parallel key:8;shaft thread:M8	M18X1.5with hout drain port	21 - 00 30	-003 1	-003 2	-003 3	-003 4	-003 5	-003 a	-003 6	-003 7	-003 8
Rhomb-flange Pilot $\Phi$ 82.55	$\Phi$ 25.,parallel key:8;shaft thread:M8	M18X1.5, Drain port M14X1.5	21 - 00 40	-004 1	-004 2	-004 3	-004 4	-004 5	-004 a	-004 6	-004 7	-004 8
Rhomb-flange Pilot $\Phi$ 82.55	$\Phi$ 25.,parallel key:8;shaft thread:M8	G1/2", Drain port M14X1.5	21 - 00 80	-008 1	-008 2	-008 3	-008 4	-008 5	-008 a	-008 6	-008 7	-008 8
Square-flange Pilot $\Phi$ 80	6D-25X22X6; shaft thread:M8	M18X1.5, drain port M14X1.5	21 - 11 10	-111 1	-111 2	-111 3	-111 4	-111 5	-111 a	-111 6	-111 7	-111 8
Rectangular-f flange Pilot $\Phi$ 85, with Dust Plate	6D-25X22X6; shaft thread:M8	M20X1.5, Drain port M14X1.5	21 - 11 40	-114 1	-114 2	-114 3	-114 4	-114 5	-114 a	-114 6	-114 7	-114 8
Rhomb-flange Pilot $\Phi$ 82.55	$\Phi$ 25.,parallel key:8;shaft thread:M8	G1/2"	21 - 01 60	-016 1	-016 2	-016 3	-016 4	-016 5	-016 a	-016 6	-016 7	-016 8
Square-flange Pilot $\Phi$ 80	$\Phi$ 25.,parallel key:8;shaft thread:M8	G1/2"	21 - 01 70	-017 1	-017 2	-017 3	-017 4	-017 5	-017 a	-017 6	-017 7	-017 8
Square-flange Pilot $\Phi$ 80, with Dust Plate	$\Phi$ 25.,parallel key:8;shaft thread:M10	M18X1.5 Drain port M14X1.5	21 - 05 20	-052 1	-052 2	-052 3	-052 4	-052 5	-052 a	-052 6	-052 7	-052 8
Rhomb-flange Pilot $\Phi$ 82.55	$\Phi$ 25.4,parallel key:6.35;shaft thread:M8	G1/2"	21 - 01 80	-018 1	-018 2	-018 3	-018 4	-018 5	-018 a	-018 6	-018 7	-018 8
Square-flange Pilot $\Phi$ 80, with Dust Plate	$\Phi$ 25.,parallel key:8;shaft thread:M8	M18X1.5 Drain port M14X1.5	21 - 01 20	-012 1	-012 2	-012 3	-012 4	-012 5	-012 a	-012 6	-012 7	-012 8
Square-flange Pilot $\Phi$ 80, with Dust Plate	$\Phi$ 25.,parallel key:8;shaft thread:M8	M18X1.5, Drain port M14X1.5	21 - 00 50	-005 1	-005 2	-005 3	-005 4	-005 5	-005 a	-005 6	-005 7	-005 8
Rhomb-flange Pilot $\Phi$ 82.55, with Dust Plate	$\Phi$ 25.,parallel key:8;shaft thread:M8	G1/2" Drain port M14X1.5	21 - 02 30	-023 1	-023 2	-023 3	-023 4	-023 5	-023 a	-023 6	-023 7	-023 8
Rhomb-flange Pilot $\Phi$ 82.55,center diatance 110.5	$\Phi$ 25.,parallel key:8;shaft thread:M8	G1/2"	21 - 01 90	-019 1	-019 2	-019 3	-019 4	-019 5	-019 a	-019 6	-019 7	-019 8
Rhomb-flange Pilot $\Phi$ 82.55	$\Phi$ 25.,parallel key:8;shaft thread:M8	G1/2" Drain port M14X1.5	21 - 03 50	-035 1	-035 2	-035 3	-035 4	-035 5	-035 a	-035 6	-035 7	-035 8
Rhomb-flange Pilot $\Phi$ 82.55	$\Phi$ 25.4,parallel key:6.35;shaft thread:M8	G1/2"	21 - 03 40	-034 1	-034 2	-034 3	-034 4	-034 5	-034 a	-034 6	-034 7	-034 8
Rhomb-flange Pilot $\Phi$ 82.55 with Dust Plate	$\Phi$ 25.,parallel key:8;shaft thread:M8	G1/2" Drain port G1/4	21 - 02 80	-028 1	-028 2	-028 3	-028 4	-028 5	-028 a	-028 6	-028 7	-028 8