

M-Maxflex Pompa / M-Maxflex Pump

Max. Vakum Seviyesi	: -92kpa (-690 mmHg)
Max. Vacuum Level	
Max. Vakum Debisi	: 11000 Nl/dak - Nl/m (660m ³ /hr)
Max. Flow Rate	
Basıncılı Hava Kaynağı	: 4-6 bar, Max, 7 bar
Supply Air Pressure	
Kaynak Hava Tipi	: Kuru basınçlı hava
Supply Air Type	Dry compressed air
Çalışma sıcaklığı	: -20°C ~ +80°C
Working Temperature	
Gürültü Seviyesi	: 55 - 68 dBA
Noise Level	

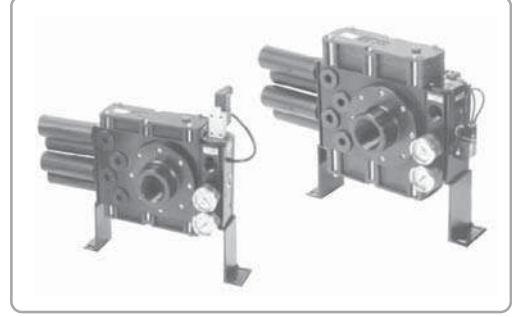

Ana Avantajları / Main Advantages

M-Maxflex pompa çeşitleri yüksek debi üretir, bütün pompalarda 2" BSP ölçüsüne kadar geniş vakum portu bulunur. Bu tip pompaların birçok uygulama çeşiti vardır özelliklerde sızdıntılı sistemlerde, delikli malzemeleri tutan sistemlerde ve büyük vakum devrelerinde kullanılır. Pompalar manifold şeklinde dizayn edilmiştir ve opsiyon olarak, dahili bağlantılı AÇMA/KAPAMA valfi kullanılabilir. Bu pompalarda da vakummetre, manometre, egzosu konumlamak için iki farklı bağlantı seçeneği ve bağlantı braketi birlikte sunulur. Hava tasarruf kiti ve VITON & EPDM conta opsiyonları da bu pompada bulunur.

This range of M-Maxflex pumps produces the very highest flow rates, as the name denotes all the pumps uses a large bore common vacuum port with port sizes up to 2" BSP. This type of pump has many applications but is particularly useful for high leakage systems, porous materials centerising vacuum system and large vacuum circuits. The pumps are based around a manifold design and utilize an integrally mounted large bore air supply on/off valve as option. The pumps also come with vacuum and air pressure gauges with two options for positioning of the exhausts, mounting brackets are also supplied. Air saving kits and VITON & EPDM seals options are also available with this pump.

Sipariş No / Order No

VTMM200EF - AS - A3 - S2-N V

1 2 3 4 5 6

1 Model-Kapasite olarak Elektrikli Pompa Eşdeğeri Model-Capacity Equivalent To Electricity Motor Pump Size
VTMM200EF - 2 KW
VTMM300EF - 3 KW
VTMM400EF - 4 KW
VTMM500EF - 5 KW
VTMM600EF - 6 KW
VTMM800EF - 8 KW
VTMM1000EF - 10 KW

2 Hava Tasarruf Kiti / Air Saving Kit
İşaretsiz / No Mark - Standart / Standard
AS - Hava Tasarruf Kitli Air saving kit attach

4 Vakum Anahtarı / Vacuum Switch
S2(P) - Dijital göstergeli iki çıkışlı / Digital display output 2points Analog kaynaksız / No analog supply
S3(P) - Dijital göstergeli iki çıkışlı / Digital display output 2points, Analog kaynaklı / Analog supply

Dikkat / Remark : S...(P)

Çıkış Tipi: PNP açık kollektör
Output type : PNP open collector

3 Hava Kaynağı Kontrol Valfi / Air Supply Control Valve
İşaretsiz - Kontrol Valfsiz / No mark - Without control valve
A1 - AC110V elektrik kumandalı valf / Electrically operated valve
A2 - AC220V elektrik kumandalı valf / Electrically operated valve
A3 - DC24V elektrik kumandalı valf / Electrically operated valve
A4 - Pnömatik kumandalı valf / Pneumatically operated valve

5 Dönüşsüz Valf / Non-Return Valve
İşaretsiz / No mark - Standart
N - Dönüşsüz Valf / Non-Return Valve

6 Sızdırmazlık/ Sealing
İşaretsiz / No Mark - Standart / Standard (NBR)
V - Viton / Viton
E - EPDM / EPDM

M-Maxflex Pompa / M-Maxflex Pump

Karakteristikler / Characteristics

Model / Model	Max. Vakum Max. Vacuum -kPa(-mmHg)	Max. Vakum Debisi (NI/dak) Max. Vacuum Flow (NI/m)her dilim eachstack	Hava Tüketimi(NI/dak) Air Consumption (NI/min) her dilim/eachstack	Gürültü Seviyesi Noise Level (dBA)	Ağırlık Weight(g)	Min. Vakum Hattı İç Çapı (2 m içinde) min. hose inner Ø (within 2m)		
						Basıncılı Hava Kaynağı Air Supply	Vakum Vacuum	Egzos Exhaust
VTMM200EF	92 (690)	2200	600-780	55-65	4270	>10	>32	>40
VTMM300EF		3300	900-1260	55-65	5584	>12	>40	>60
VTMM400EF		4400	1200-1680	55-65	5939	>12	>40	>60
VTMM500EF		5500	1500-2100	65-68	6275	>14	>45	>70
VTMM600EF		6600	1800-2520	65-68	11579	>14	>50	>70
VTMM800EF		8800	2400-3360	65-68	12300	>15	>50	>75
VTMM1000EF		11000	3000-4140	65-68	15800	>18	>65	>90

Üretilen Vakum (NI/dak) / Induce Air in Liters Per Minute (NI/m)

Model	-mmHg -Kpa	0	75	150	225	300	375	450	525	600	675
	0	10	20	30	40	50	60	70	80	90	
VTMM200EF	2200	1540	1016	528	290	216	144	80	40	6.4	
VTMM300EF	3300	2310	1781	793	435	324	216	120	60	9.6	
VTMM400EF	4400	3080	2036	1058	580	432	288	160	80	12.8	
VTMM500EF	5500	3850	2545	1323	725	540	360	200	100	16	
VTMM600EF	6600	4620	3055	1588	870	648	432	240	120	19.2	
VTMM800EF	8800	6164	4076	2119	1160	864	576	320	160	25.6	
VTMM1000EF	11000	7700	5090	2646	1450	1080	720	400	200	32	

Vakum Seviyesine Ulaşma Zamanı (s/lt) / Time in Seconds to Evacuate to Vacuum Level (sec/l)

Model	-mmHg -Kpa	75	150	225	300	375	450	525	600	675
	10	20	30	40	50	60	70	80	90	
VTMM200EF	0.0031	0.0075	0.0164	0.029	0.054	0.09	0.153	0.274	0.67	
VTMM300EF	0.0023	0.0056	0.0123	0.022	0.041	0.068	0.115	0.206	0.503	
VTMM400EF	0.0015	0.0038	0.0082	0.014	0.027	0.045	0.076	0.137	0.335	
VTMM500EF	0.0013	0.0033	0.0072	0.013	0.024	0.04	0.067	0.120	0.294	
VTMM600EF	0.0012	0.0028	0.0062	0.011	0.021	0.034	0.057	0.103	0.252	
VTMM800EF	0.0008	0.0019	0.0041	0.007	0.014	0.022	0.038	0.068	0.168	
VTMM1000EF	0.0007	0.0016	0.0036	0.006	0.012	0.018	0.031	0.057	0.147	