

WAC - Serisi ISO 15552 Silindirler / WAC -Series ISO 15552 Cylinders

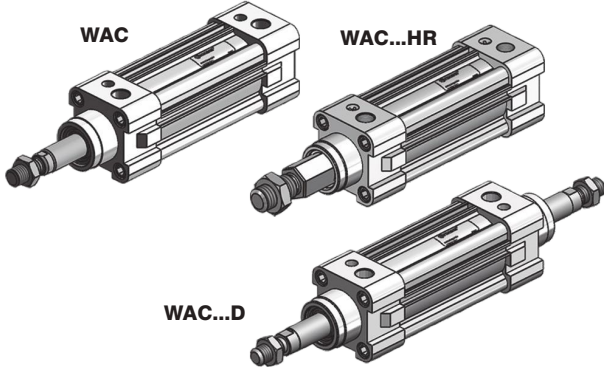

Özellikler / Specification

Piston Çapı / Bore Size	32	40	50	63	80	100	125
Çalışma Tipi / Acting Type	Çift Etkili / Double Acting						
Akışkan / Fluid	Hava (40µm filtrelenmiş) / Air (40µm filtered)						
Çalışma Basıncı / Op. Pressure	< 10 Bar						
Sıcaklık / Temperature	0 ~ +80 °C						
Manyetik / Magnetic	Opsiyonel / Optional						
Yastıklama Tipi / Cush. Type	Ayarlı Yastıklama / Adjustable Cushinoed						
Hız / Speed Range	< 800 mm/s						
Sensör / Sensör Switches	WT-50 / WT-65 / WT-75						

Teknik Çizim / Technical Drawing

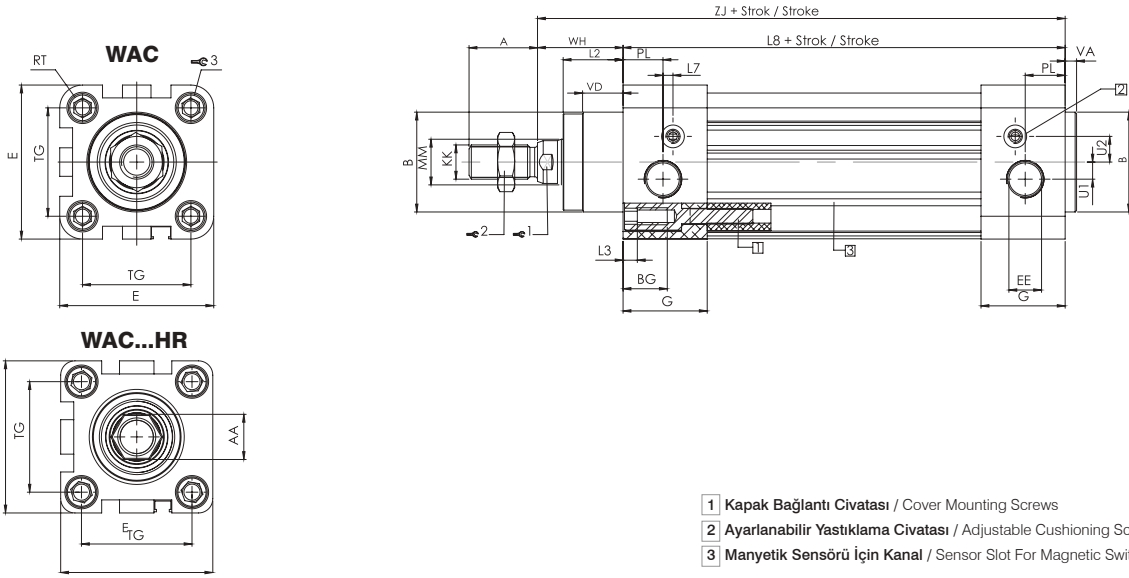

Ø mm	A -0.5	B Ø d11	BG min.	E +0.5	EE G1/8"	G -0.2	U2 ±0.1	U1 ±0.1	KK	L2	L3 max.	L7	L8 ±0.4	MM Ø	PL ±0.1	RT	TG ±0.3	VA +0.5	VD +2.2	WH +1.8	ZJ +1.8	ZM +1.8	AA	1	2	3	YASTIK BOYU CUSH. LENG.	MAX. STROK MAX. STROKE
32	22	30	15	46	G1/8"	25.0	6.0	5.0	M10X1.25	18.0-0.2	5	2.5	94	12	15.5	M6	32.5	4	14.5	26	120	146	10	10	16	6	18.9	2000
40	24	35	15	54	G1/4"	29.5	8.5	6.0	M12X1.25	21.0-0.2	5	3.5	105	16	14.0	M6	38.0	4	14.5	30	135	165	14	14	18	6	25.5	2000
50	32	40	18	64	G1/4"	29.5	10.0	8.5	M16X1.50	28.0-0.2	5	5.0	106	20	14.0	M8	46.5	4	16.0	37	143	181	19	17	24	8	20.4	2000
63	32	45	18	75	G3/8"	35.5	12.5	9.5	M16X1.50	28.5-0.2	6	6.5	121	20	17.0	M8	56.5	4	16.0	37	158	196	19	17	24	8	22.3	2000
80	40	45	22	93	G3/8"	36.0	12.5	8.0	M20X1.50	34.7-0.2	6	11.5	128	25	15.0	M10	72.0	4	19.5	46	174	220	23	21	30	10	27.2	2000
100	40	55	22	110	G1/2"	39.0	12.0	10.0	M20X1.50	38.2-0.2	6	6.5	138	25	20.0	M10	89.0	4	19.5	51	189	239	23	21	30	10	30.4	2000
125	54	60	22	136	G1/2"	45.0	12.0	8.0	M27X2.00	46.0-0.3	-	13.0	160	32	19.0	M10	110.0	6	26.5	65	225	291	-	27	41	19	29.8	2000

Sipariş Kodu / Ordering Code

MODEL	OPSİYON OPTIONS	MANYETİK MAGNETIC	YASTIKLAMA CUSHONING	ÇAP DIA.	STROK STROKE	STROK STROKE	MİL MALZEMESİ ROD MATERIAL	MİL UZUNLUĞU ROD LENGHT	DİŞ TİPİ SCREW TYPE	DİŞ ÖLÇÜSÜ SCREW SIZE	DİŞ UZUNLUĞU SCREW LENGHT
WAC	D	M	YY	Ø80	Ø250	Ø050	SS	L25	F	ZM18.H1.5	E15

BOŞ : STANDART	- Blank Standart	BOŞ :MANYETİKSİZ	BOŞ :YASTIKSIZ	PISTON ÇAP (mm)	STROK (mm)	STROK (mm)	SS :PASLANMAZ	LX (mm)	F :DİŞİ	Zx :ÇAP	Ex (mm)
T : TANDEM	- Tandem	Blank :Without Magnet	Blank :Uncushioned	Piston Dia	Stroke	Stroke	Inox	-	Female	Dia	
D : POZİSYONER	- Positioner										
PT : ÇİFT MİLLİ	- Through Rod	M :MANYETİK	YY :YASTIKLI				SADECE POZİSYONER İÇİN	BOŞ :STANDART	BOŞ :STANDART	BOŞ :STANDART	BOŞ :STANDART
J : STROK AYARLI	- Stroke Adjustable	M :With Magnet	YY :Cushinoed				Blank :Standart	Blank :Standart	Blank :Standart	Hx :Havne	Blank :Standart
HR : DÖNMEZ MİLLİ	- Hexagonal Rod									Pitch	
FS : ÖN DEN YAYLI	- Front Spring										BOŞ :STANDART
(50mm ye Kadar)	(Up to 50mm)										Blank :Standart
RS : ARKADAN YAYLI	- Rear Spring										
(50mm ye Kadar)	(Up to 50mm)										
LF : DÜŞÜK SÜRTÜNME	- Low Friction										
V : SICAĞA DAYANIKLI	- Heat Resistance										
150° Sıcaklığa Kadar	(Up to 150°C)										
LR : YAĞDA ÇALIŞABİLEN	- Hydropneumatic										
6 Bar Basıncı Yağda	(6 bar oil pressure)										

WAC...T Tandem Silindirler / WAC...T Tandem Cylinders

Teknik Çizim / Technical Drawing

WAC.M.YY.040.0050.T

Ø Strok / Stroke

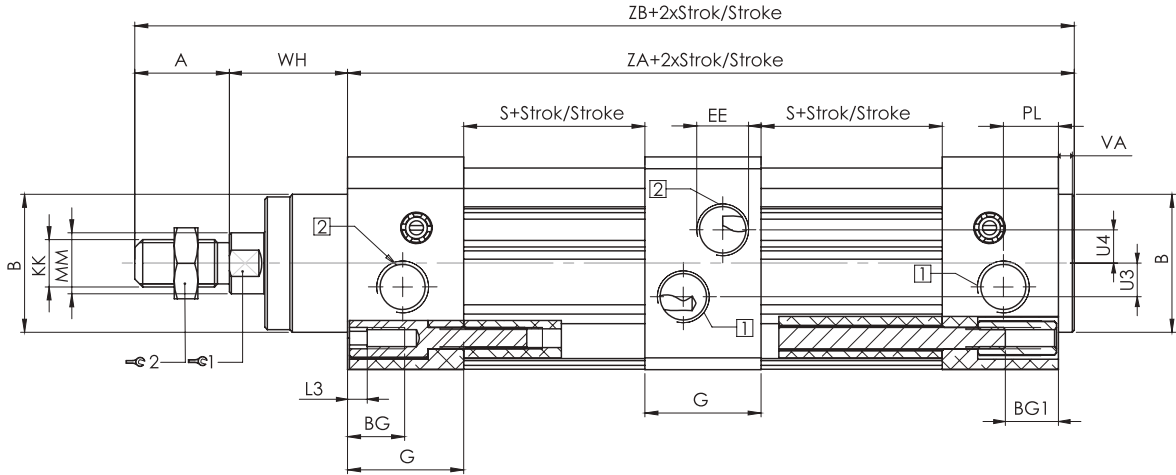
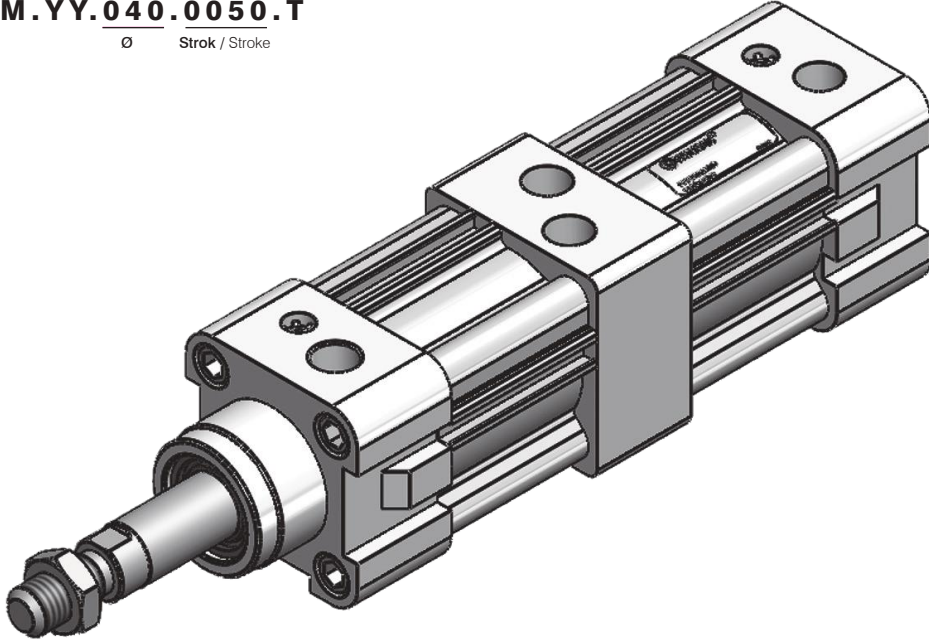

NOT :WAC silindir sayısından sipariş ediniz. / 200 stroktan sonra sensör bilgisi alınır.
NOTE :Order from WAC cylinders page. / Contact us for the strokes over than 200

1 Silindir Mili İleri / Cylinder Rod Advancing
2 Silindir Mili Geri / Cylinder Rod Retracting

Ø mm	KK	L3	BG1	G	U3 ±0.1	U4 ±0.1	PL ±0.1	VA	ZB	ZA	S ±0.4	3
32	M10X1.25	5	12.5	25.0	7.0	7.0	15.5	4	215.0	163.0	44	10
40	M12X1.25	5	12.5	29.5	8.5	8.5	14.0	4	238.5	180.5	46	14
50	6X1150	5	14.0	29.0	10.0	10.0	14.0	4	253.0	180.0	46	17
63	6X1150	6	14.0	35.0	14.0	14.0	17.0	4	279.0	206.0	50	17
80	M20X1.50	6	16.0	36.0	15.0	15.0	15.0	4	310.0	220.0	56	21
100	M20X1.50	6	16.0	40.0	25.0	25.0	20.0	4	335.0	240.0	61	21
125	M27X2.00	-	24.0	43.0	25.0	25.0	19.0	6	400.0	275.0	71	27

WAC...PT Pozisyoner Silindirler / WAC...PT Positioner Cylinders

Teknik Çizim / Technical Drawing

WAC.M.YY.040.0050.0025.PT

Ø S1 S2

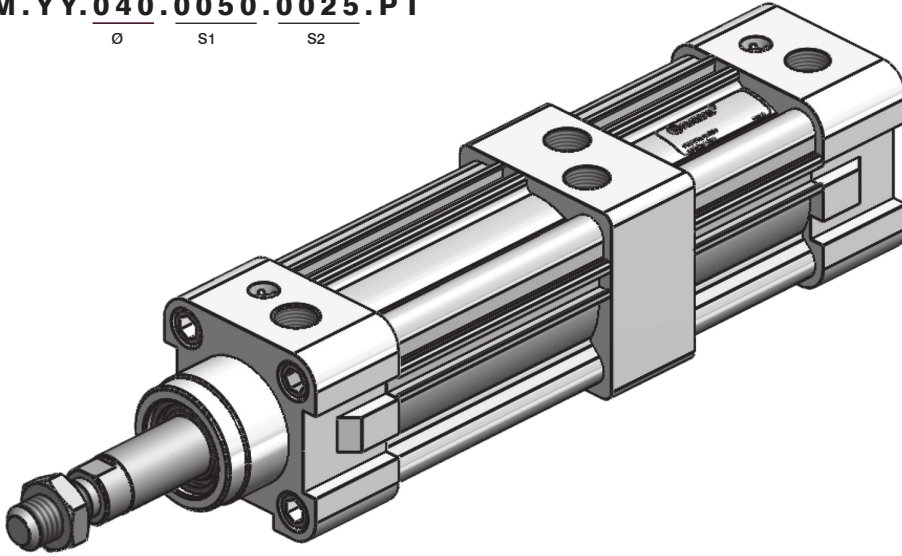

S1: Pozisyon 1 / Position1
S2: Pozisyon 2 / Position2

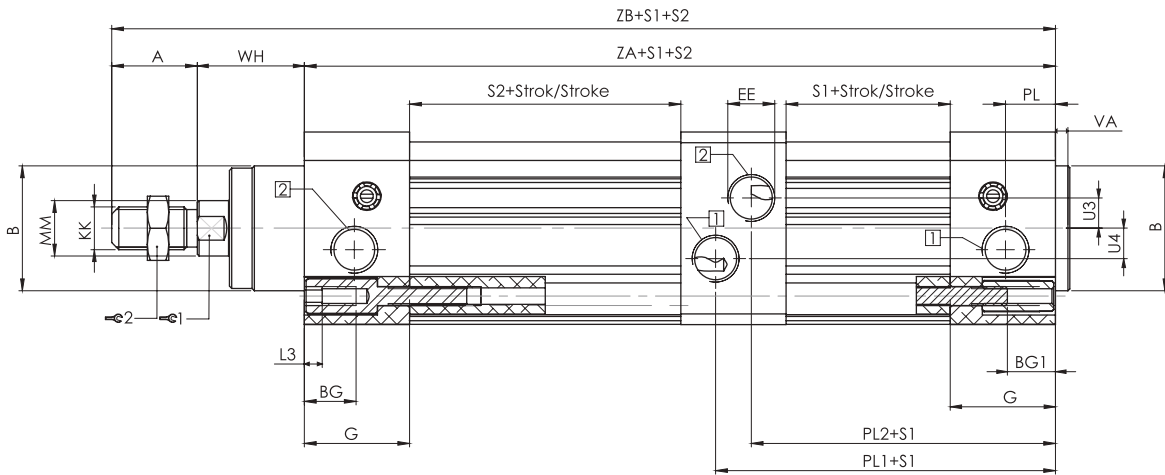

- 1 Silindir Mili İleri / Cylinder Rod Advancing
2 Silindir Mili Geri / Cylinder Rod Retracting

NOT :WAC silindir sayfasından sipariş ediniz. / 200 stroktan sonra sensör bilgisi alınır.
NOTE :Order from WAC cylinders page. / Contact us for the strokes over than 200

Ø mm	KK	L3	BG1	G	U3 ±0.1	U4 ±0.1	PL ±0.1	VA	ZB	ZA	S1 ±0.4	PL1 ±0.2	PL2 ±0.2
32	M10X1.25	5	12.5	25.0	7.0	7.0	15.5	4	215.0	163.0	44	86.5	76.5
40	M12X1.25	5	12.5	29.5	8.5	8.5	14.0	4	238.5	180.5	46	95.2	85.2
50	M16X1.50	5	14.0	29.0	10.0	10.0	14.0	4	253.0	180.0	46	95.0	85.0
63	M16X1.50	6	14.0	35.0	14.0	14.0	17.0	4	279.0	206.0	50	108.0	98.0
80	M20X1.50	6	16.0	36.0	15.0	15.0	15.0	4	310.0	220.0	56	105.0	115.0
100	M20X1.50	6	16.0	40.0	25.0	25.0	20.0	4	335.0	240.0	61	115.0	125.0
125	M27X2.00	-	24.0	43.0	25.0	25.0	19.0	6	400.0	275.0	71	142.5	132.5

WAC...D Çift Milli Silindirler / WAC...D Through Rod Cylinders

Teknik Çizim / Technical Drawing





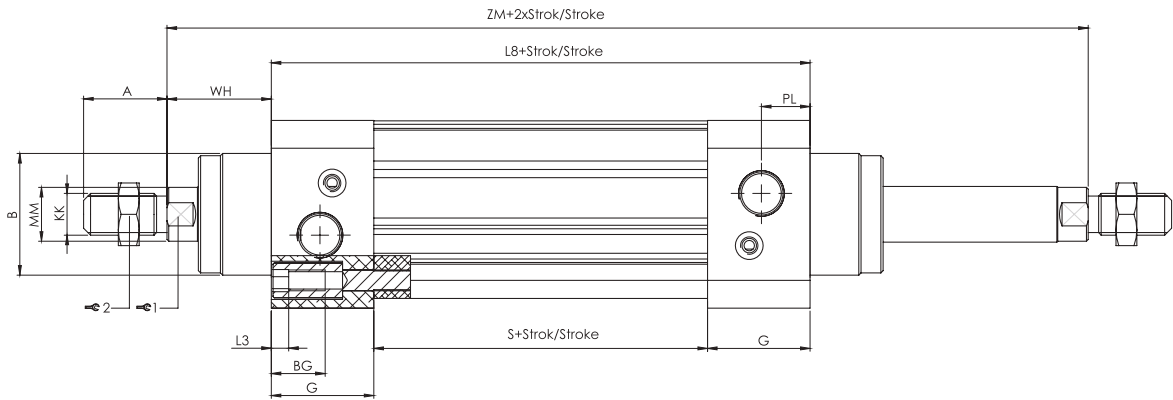
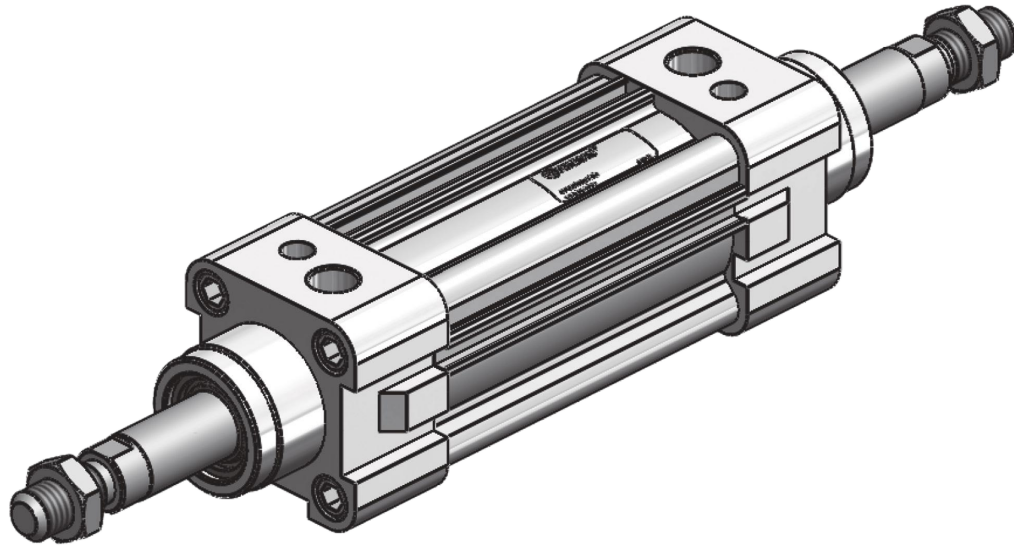





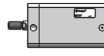

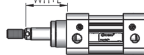

WAC.M.YY.040.0050.D

Ø Strok / Stroke

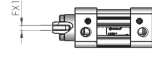
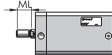
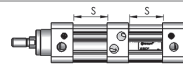
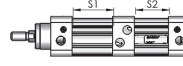

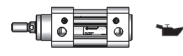
Ø mm	A -0.5	B Ø d11	WH +2.2	PL ±0.1	S ±0.4	G -0.2	KK	MM Ø	L3 Max	BG Min
32	22	30	26	15.5	44	25.0	M10X1.25	12	5	15
40	24	35	30	14.0	46	29.5	M12X1.25	16	5	15
50	32	40	37	14.0	46	29.5	M16X1.50	20	5	18
63	32	45	37	17.0	50	35.5	M16X1.50	20	6	18
80	40	45	46	15.0	56	36.0	M20X1.50	25	6	22
100	40	55	51	20.0	61	39.0	M20X1.50	25	6	22
125	54	60	65	19.0	71	45.0	M27X2.00	32	-	22

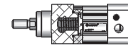
Opsiyonlar / Options

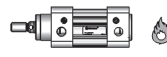
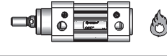
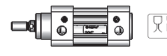
Sembol / Symbol	Özellik / Explanation	Kodlama / Coding	Çizim / Drawing
Standart	—	—	
Standart	—	—	
M	Manyetik / Magnetic	M	
YY	Yastıklı / Cushioned	YY	
L	Mili Uzun / Long Rod	.L50	
E	Farklı Diş Boyu / Special Thread Length	.E47	
X1	Mil Ucu Dişi Kesik / Threadless	.X1	
Z...H	Farklı Diş Ölçüsü / Special Thread Size	.ZM10.H.1.25	
F1	Dişi Dişli / Female Thread	.F1.Z.M8	
FX1	Dişi Dişli, Mil Ucu Kesik / Special Female Thread	.FX1.Z.M8	
ML	Erkek Dişli / Male Thread	.ML	
T	Tandem / Tandem	.050.0100.T	
PT	Pozisyoner / Positioner	.050.0040.0025.PT	
J	Strok Ayarlı / Stroke Adjustable	.J	
D	Çift Millî / Through Rod	.D	
LR	Yağda Çalışabilen / Hydropneumatic	.LR	
LF	Düşük Sürtünmeli / Low Friction	.LF	
RS	Arka Yaylı / Rear Spring	.RS	
FS	Ön Yaylı / Front Spring	.FS	
SS	Paslanmaz Millî / Inox Rod	.SS	
V	Viton Keçeli / Viton Seal	.V	
VO	Viton Boğaz Keçeli / Viton Rod Seal	.VO	
FD	Gıdaya Uyumlu Yağlanmış / Greased Suitable Food	.FD	
C	Soğuğa Dayanım / Low Temperature	.C	