

**WINMAN Solenoid Valf (5/2 yollu ) / Solenoid Valve (5/2 way)**

**4M (Namur) Serisi / 4M (Namur) Series**



**Sembol / Symbol**



**Ürün Özelliği / Product Feature**

1. Internally piloted structure.
2. Structure in sliding column mode: good tightness and sensitive reaction.
3. Double control solenoid valves have memory function.
4. Internal hole adopts special processing technology which has little attrition friction, low start pressure and long service life.
5. No need to add oil for lubrication.
6. Install in the side plate with the surface upward, which can be used by directly connecting with the actuators.
7. Affiliated manual devices are equipped to facilitate installation and debugging.
8. Several standard voltage grades are optional.

**Akış Şeması / Flow Chart**

Please refer to the same types of 4V series solenoid valves.

**Sipariş Kodu / Ordering Code**

**Özellikler / Specification**

Model	4M110-M5 4M120-M5	4M110-06 4M120-06	4M210-06 4M220-06	4M210-08 4M220-08	4M310-08 4M320-08	4M310-10 4M320-10
Fluid	Air(to be filtered by 40 µm filter element)					
Acting	Internal pilot					
Port size [Note1]	In=Out=M5	In=Out=1/8"	In=Out=1/8"	In=1/4" Out=1/8"	In=Out=1/4"	In=3/8" Out=1/4"
Orifice size	5.5mm <sup>2</sup> (Cv=0.31)	12.0mm <sup>2</sup> (Cv=0.67)	14.0mm <sup>2</sup> (Cv=0.78)	16.0mm <sup>2</sup> (Cv=0.89)	25.0mm <sup>2</sup> (Cv=1.40)	30.0mm <sup>2</sup> (Cv=1.68)
Valve type	5 port 2 position					
Operating pressure	0.15~0.8MPa(21~114psi)					
Proof pressure	1.2MPa(175psi)					
Temperature	-20~70°C					
Material of body	Aluminum alloy					
Lubrication [Note2]	Not required					
Max.frequency[Note3]	5 cycle/sec				4 cycle/sec	
Weight (g)	4M110:120	4M120:175	4M210:220	4M220:320	4M310:310	4M320:400

[Note1] PT thread, G thread and NPT thread are available.

[Note2] Once lubricated air is used, continue with same medium to optimise valve life span. Lubricants like ISO VG32 or equivalent are recommended.

[Note3] The maximum actuation frequency is in the no-load state.

**Bobin Özellikler / Coil Specification**

Item	4M110		4M120		4M210		4M220		4M310		4M320	
Standard voltage	AC220V	AC110V	AC24V	DC24V	DC12V	AC220V	AC110V	AC24V	DC24V	DC12V		
Scope of voltage	AC: ± 15%				DC: ± 10%							
Power consumption	3.5VA	3.5VA	4.0VA	2.5W	2.5W	4.5VA	4.5VA	5.0VA	3.0W	3.0W		
Protection	IP65(DIN40050)											
Temperature classification	B Class											
Electrical entry	Terminal, Grommet											
Activating time	0.05 sec and below											

4M 3 10 10 A □ □



□ Model	□ Code	□ Valve type	□ Port size	□ Voltage	□ Electrical entry	□ Thread type
4M: Solenoid valve (5/2 way NAMUR type)	1: 100 Series	10: Single solenoid 20: Double solenoid	M5: M5	A: AC220V B: DC24V C: AC110V E: AC24V F: DC12V	Blank: Terminal I: Grommet	No this code
	2: 200 Series		06: 1/8"			Blank: PT G: G T: NPT
	3: 300 Series		06: 1/8" 08: 1/4" 08: 1/4" 10: 3/8"			

**İç Yapı / Inner Structure**

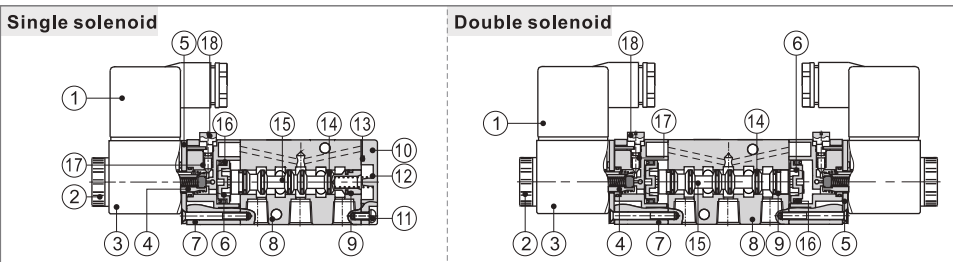

No.	Item	No.	Item
1	Connector	10	Bottom cover
2	Coil net	11	Fixed screw
3	Coil	12	Spool spring
4	Armature	13	Bottom cover gasket
5	Fixed plate	14	Spool O-ring
6	Piston	15	Spool
7	Pilot kit	16	Piston O-ring
8	Body	17	Override spring
9	Wear ring	18	Manual override

**WINMAN Solenoid Valf (5/2 yollu) / Solenoid Valve (5/2 way)**

**4M (Namur) Serisi / 4M (Namur) Series**

**4M110(Terminal)**

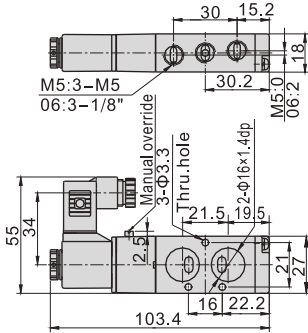

**4M210(Terminal)**

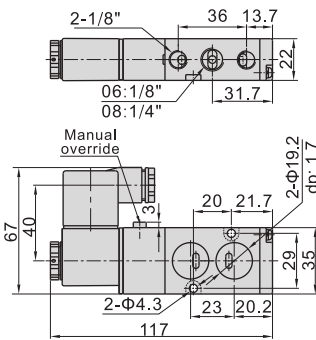

**4M310(Terminal)**

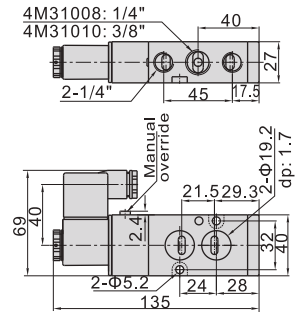

**4M120(Terminal)**

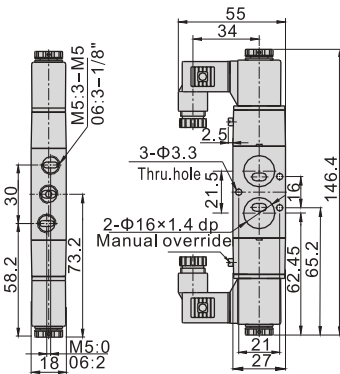

**4M220(Terminal)**

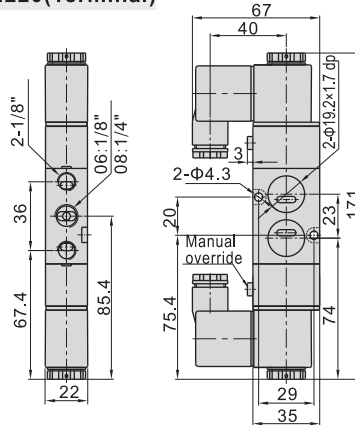

**4M320(Terminal)**

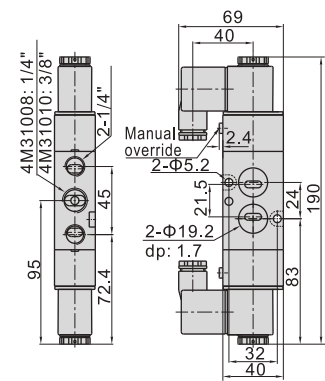

**4M110(Grommet)**

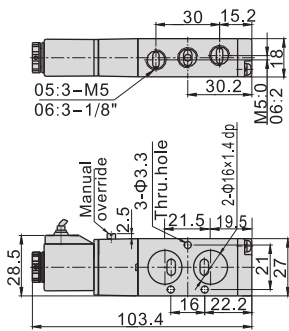

**4M210(Grommet)**

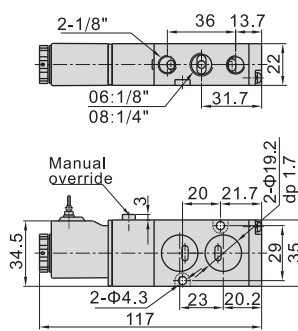

**4M310(Grommet)**

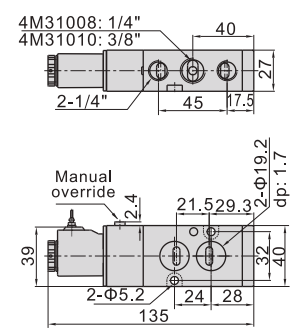

**4M120(Grommet)**

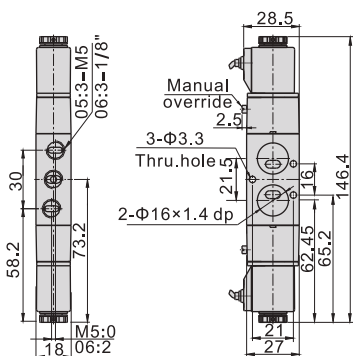

**4M220(Grommet)**

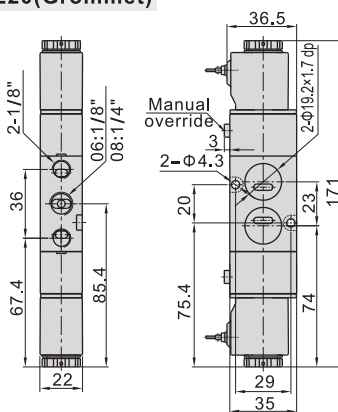

**4M320(Grommet)**

