

WINMAN ISO VALFLER WIVS SERİLERİ

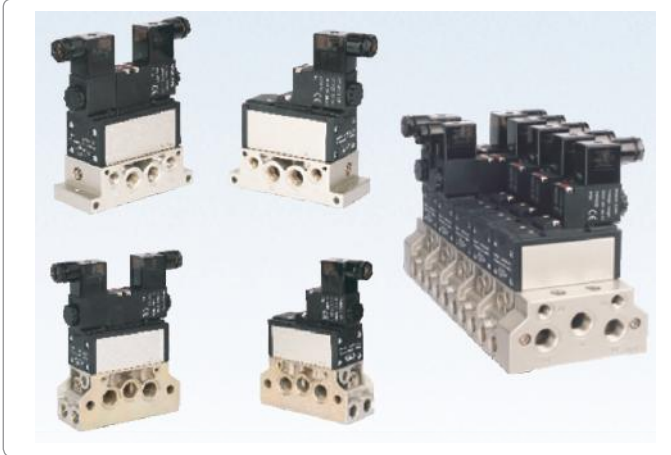

Özellikler / Specification

Model	200Series	300 Series	400 Series	600 Series
Orifice size(Cv) mm ²	32(Cv=1.8)	42(Cv=2.32)	69(Cv=3.85)	108(Cv=6.0)
Fluid	Air(to be filtered by 40 μm filter element)			
Acting	Internal pilot or external pilot			
Lubrication ①	Not required			
Operating Pressure	Internal pilot	0.2~1.0Mpa(29~145psi)		
	External pilot	0~1.0Mpa(0~145psi)		
Control pressure(External pilot)	0.2~1.0Mpa(29~145psi)			
Proof pressure	1.5Mpa(215psi)			
Temperature	-20~70 °C			
Port size(manifold) ②	1/4"	3/8"	1/2"	3/4"
Port size(end plate)	3/8"	1/2"	3/4"	1"
Voltage range	AC:±15%		DC:±10%	
	AC:3.5VA		DC:3.0W	
Power consumption				
Activating time	10\20 Series	33\41ms	42\55ms	50\68ms
	30 C\E\IP Series	38\50ms	52\62ms	52\68ms
(0.5MPa)Open/close				
Insulation	Class B			
Protection	IP65			
Installation size	ISO5599-4 standard			

① Note: Once lubricated air is used, continue with same medium to optimise valve life span. Lubricants like ISO VG32 or equivalent are recommended.

② Note: PT thread and G thread are available.

Symbol

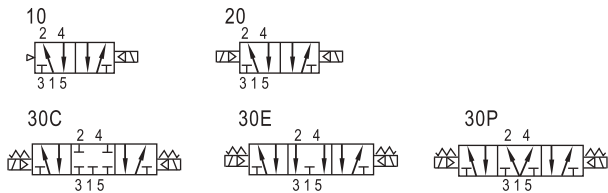

Product feature

1. Succinct appearance and compact conformation.
2. The installation size conforms to ISO 5599/1 standard.
3. Because of the special seals, the feature are large flow rate and long lifetime.
4. For 200\300\400 series you can adjust the installation direction of the gasket to change the acting type: internal pilot, external pilot, or air control.
5. You need install the valve together with the sub-base. There are individual and parallel type for manifold sub-base.
6. There are various connection and installation method for manifold. It is easy to use.
7. The manifold of 200\300\400 series have the function of exhaust throttling, so no need to connect another throttle valve.

Ordering Code

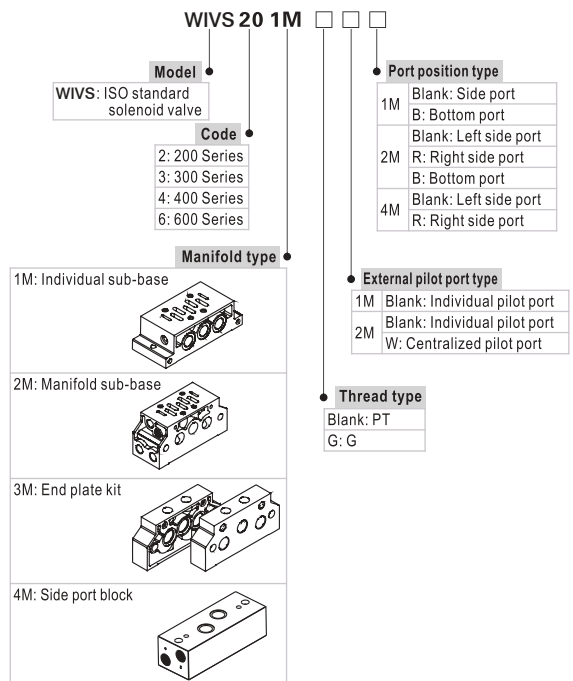

- Note: 1. For the same model, the port size of the end-plate is bigger than the sub-base (For example ESV202M, the port size of sub-base is 1/4", and the port size of end plate is 3/8").
2. Only individual pilot port is available for individual sub-base.
3. The manifold sub-base must be used with end plate kit, individual pilot port and centralized pilot port can be mixed.
4. 600 series individual sub-base only has side port, 600 series manifold sub-base only has individual pilot port and bottom port.
5. Only 600 series have side port block.

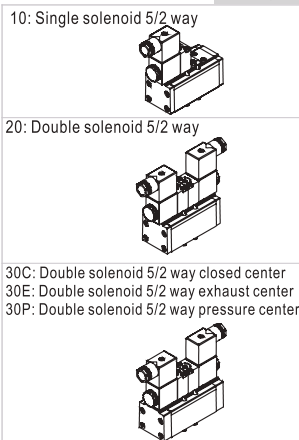
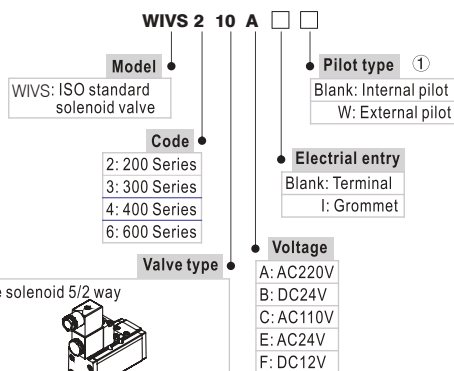

① Note: Internal pilot can be changed to external pilot mode(except 600 series), please adjust the installation method of the gasket referring to article 1 o 2 in the installation manual.

Ordering code of accessories

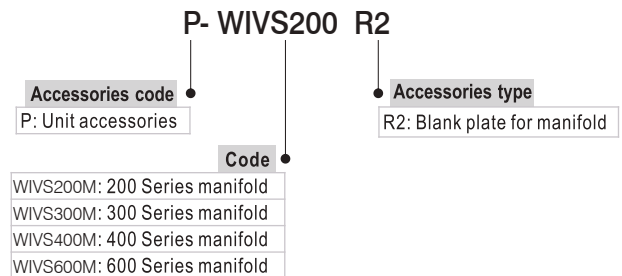

WINMAN ISO VALFLER WIVS SERİLERİ

Installation and operation(For 200, 300, 400 series)

1. The classification and selection for the pilot type of valve

1.1. According to the source of pilot air, we can divide the valve into two types: the internal pilot and external pilot. The standard type is internal pilot.

1.2. You can convert from internal pilot to external pilot by the following methods.

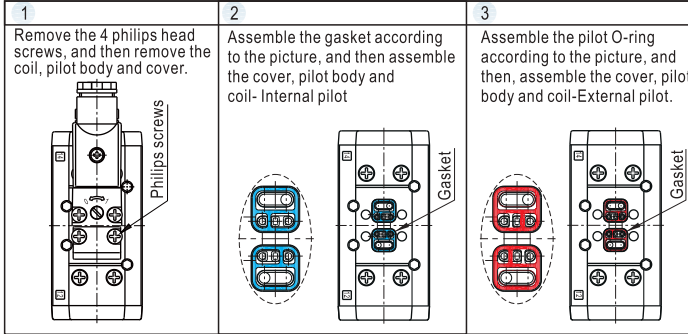

2. The classification and selection for the parallel manifold sub-base

2.1. According to the direction of pilot air supply, we can divide the manifold sub-base into two types: the individual pilot and centralized pilot.

2.2. If you select the individual pilot, the fitting must be connected to the individual pilot ports.

If you select the centralized pilot type, the fitting must be connected to the centralized pilot ports.

2.3. If you use parallel manifold, all of the manifold must be used the same pilot type: such as, all of them are the individual pilot type, or all of them are the centralized pilot type.

* Note: Only when you use the external pilot type, you can select the individual pilot or centralized pilot.

When you use the internal pilot type, the pilot ports on the manifold are ineffective.

3. The position and specification of the manifold sub-base ports

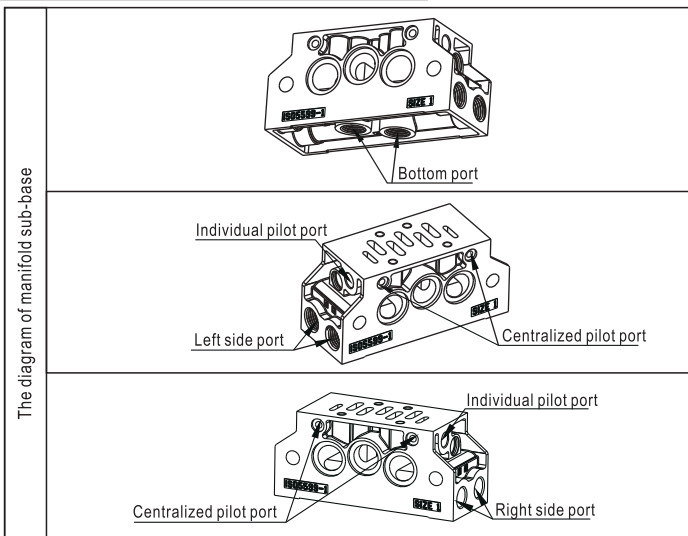

Port status of manifold sub-base

Port working name condition	Left side port	Right side port	Bottom port	Centralized pilot port	Individual pilot port
Ordering code					
WIVS202MG	Use	Unused	Unused	Unused	Use
WIVS202MGR	Unused	Use	Unused	Unused	Use
WIVS202MGB	Unused	Unused	Use	Unused	Use
WIVS202MGW	Use	Unused	Unused	Use	Unused
WIVS202MGWR	Unused	Use	Unused	Use	Unused
WIVS202MGWB	Unused	Unused	Use	Use	Unused

Note: Please seal the bottom port by plug, when it is unused.

The above list is an example of 200M series' ordering code, the other series is follow the same pattern, only need to change the series code.

4. Exhaust throttle function

4.1. The manifold has exhaust throttle function, the below picture shows the position of the exhaust throttle orifices on each side.

4.2. Use allen key to adjust the screw.

4.3. Rotate the screw clockwise to reduce the exhaust orifice, rotate the screw counter-clockwise to enlarge the exhaust orifice.

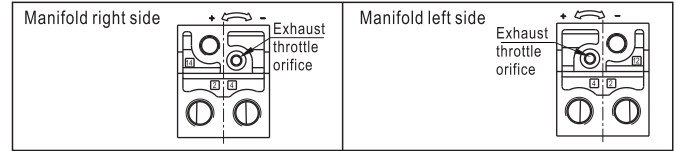

Flow chart

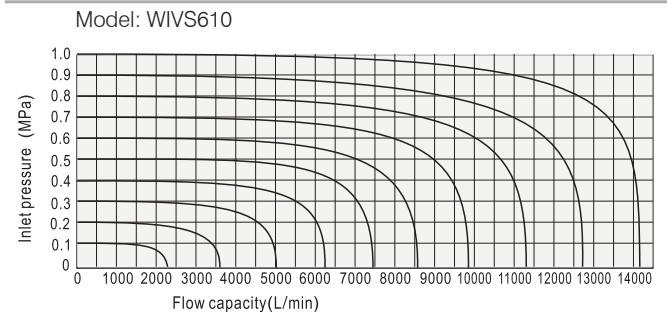
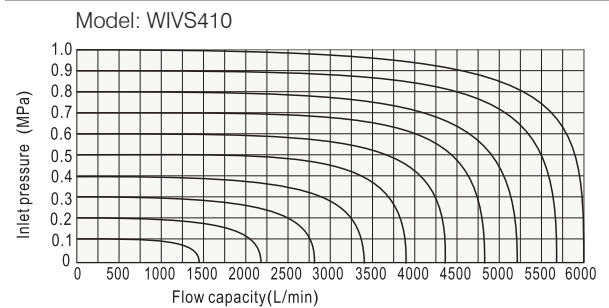
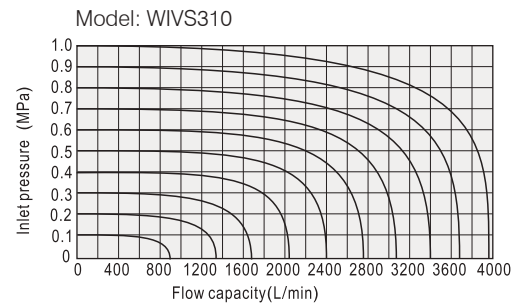
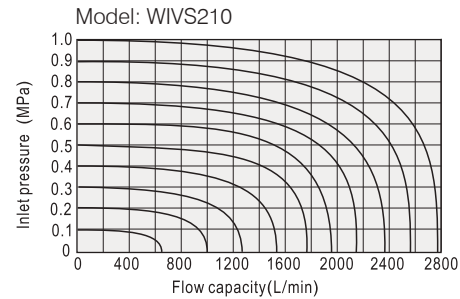

WINMAN ISO VALFLER WIVS SERİLERİ

Inner structure

WIVS210 (Terminal)

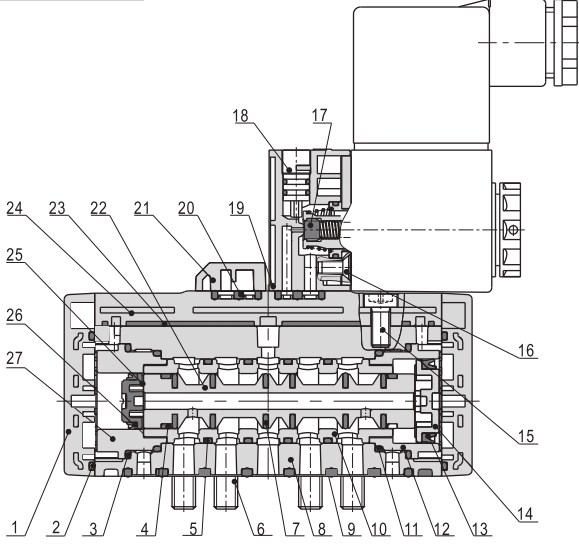

NO.	Item	NO.	Item	NO.	Item
1	Bottom cover	10	Spacer	19	Pilot kit
2	O-ring	11	O-ring	20	Gasket
3	O-ring	12	Big piston sheath	21	Cover plate
4	Wear ring	13	Big piston O-ring	22	Spool
5	O-ring	14	Big piston	23	Upper cover gasket
6	Screw	15	Screw	24	Upper cover
7	O-ring	16	Screw	25	Small piston
8	Body	17	Gasket	26	Small piston O-ring
9	Gasket	18	Manual override	27	Small piston sheath

Dimensions (WIVS200 Series)

WIVS210 (Terminal)

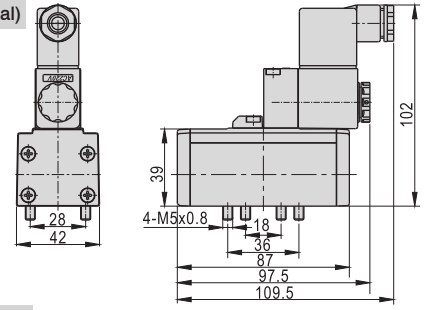

WIVS210 (Grommet)

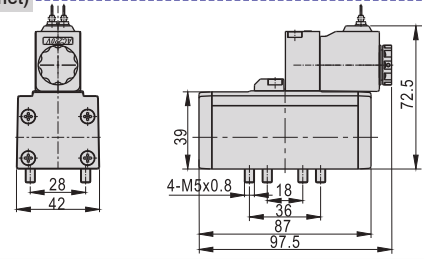

WIVS220 (Terminal)

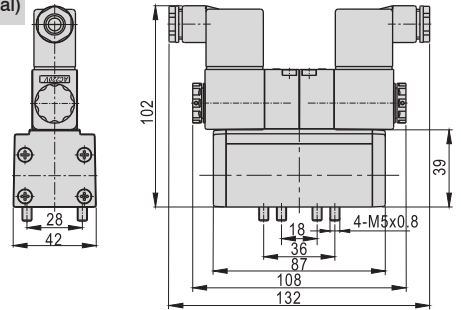

WIVS220 (Grommet)

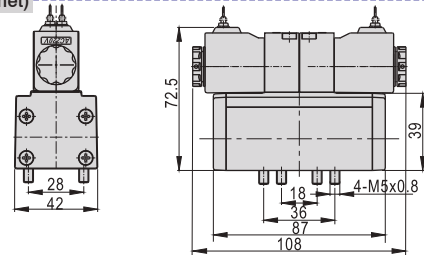

WIVS230 (R/P)(Terminal)

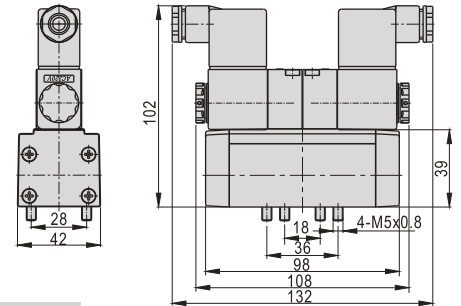

WIVS230C (E/P)(Grommet)

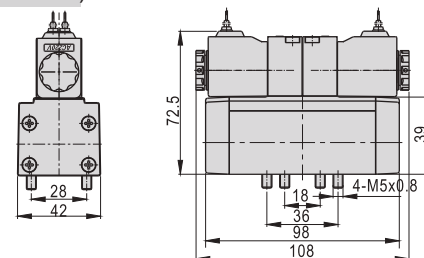

WINMAN ISO VALFLER WIVS SERİLERİ

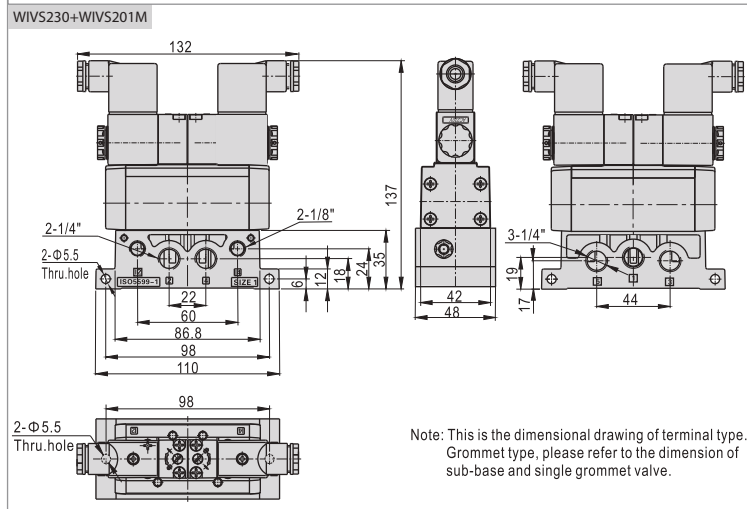
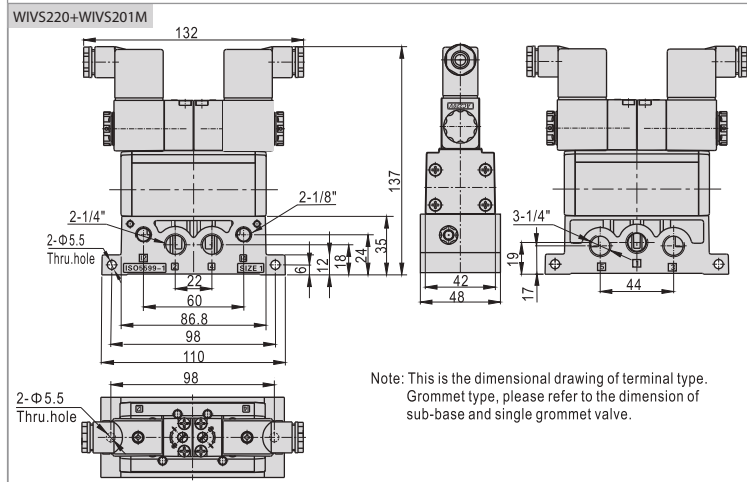
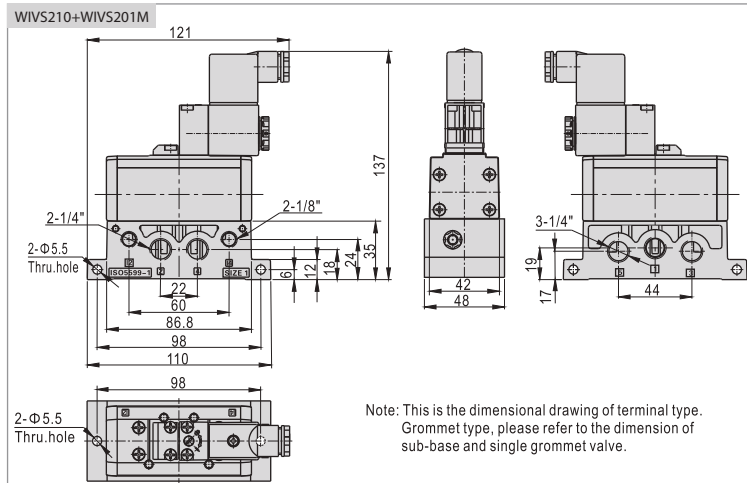
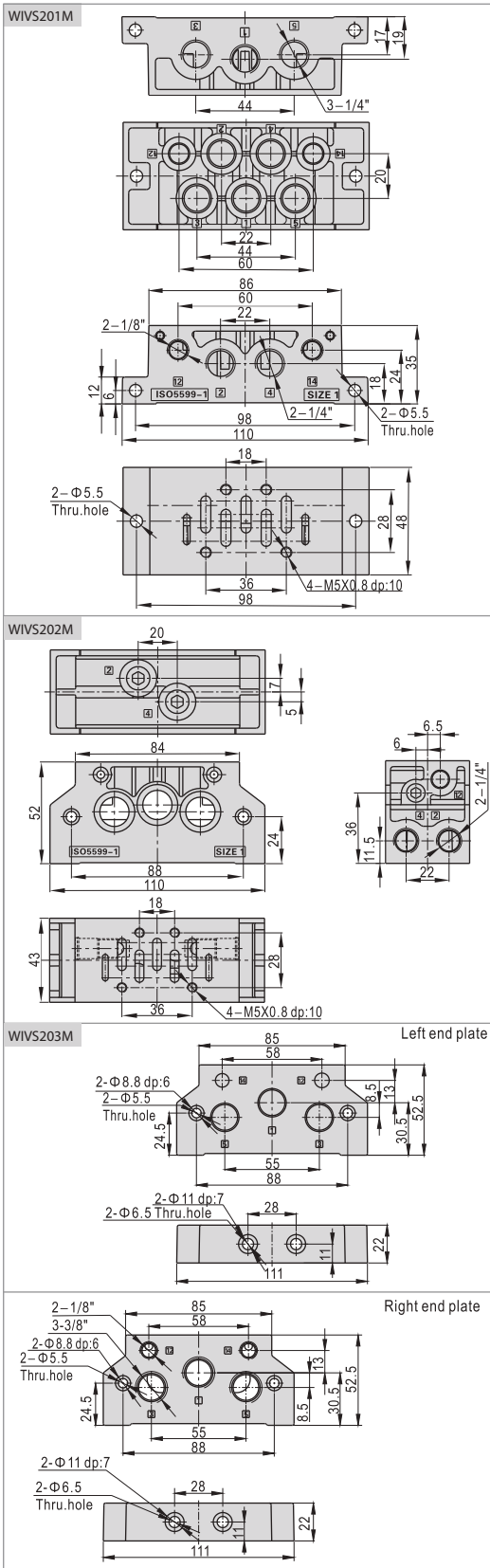

WINMAN ISO VALFLER WIVS SERİLERİ

WIVS210+WIVS202M+WIVS203M

Note: n means the number of stations. The dimension of the grommet type (more than 3 stations), please refer to this drawing and the single grommet valve drawing.

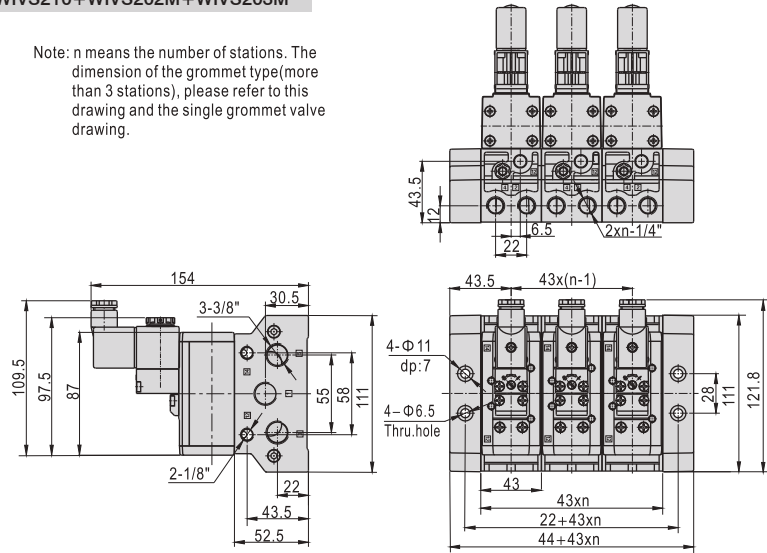

WIVS220+WIVS202M+WIVS203M

Note: n means the number of stations. The dimension of the grommet type (more than 3 stations), please refer to this drawing and the single grommet valve drawing.

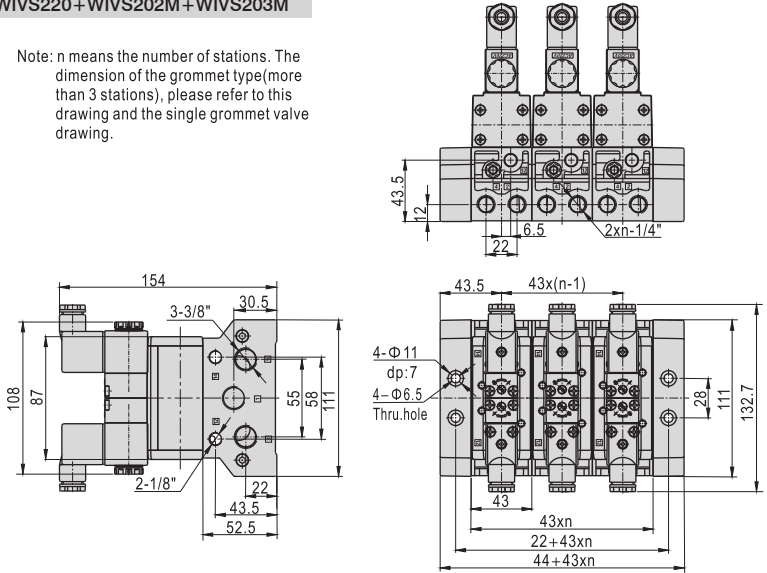

WIVS230+WIVS202M+WIVS203M

Note: n means the number of stations. The dimension of the grommet type (more than 3 stations), please refer to this drawing and the single grommet valve drawing.

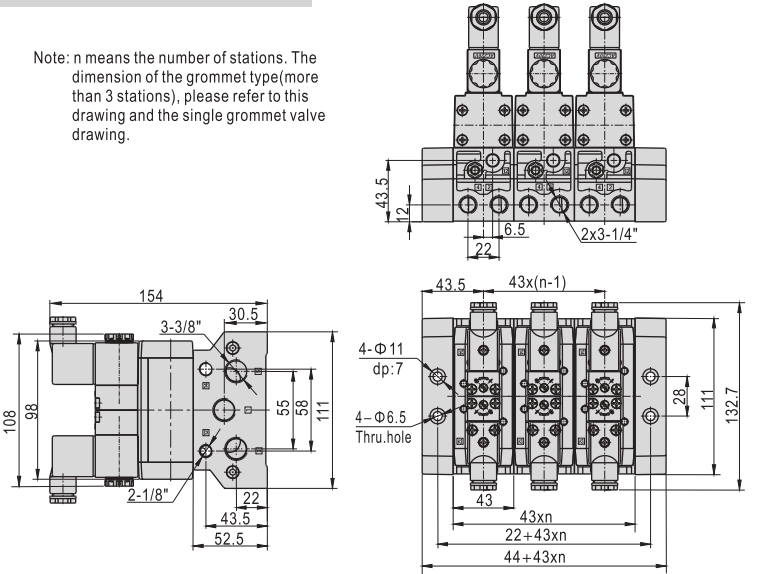

Dimensions (WIVS300 Series)

WIVS310(Terminal)

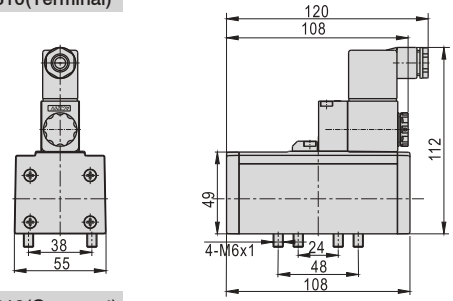

WIVS310(Grommet)

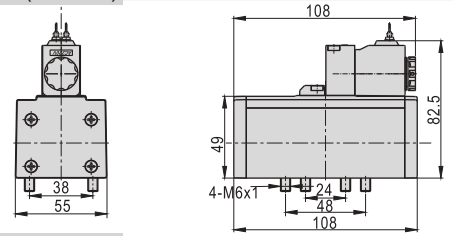

WIVS320(Terminal)

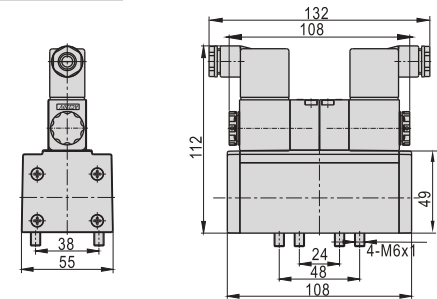

WIVS320(Grommet)

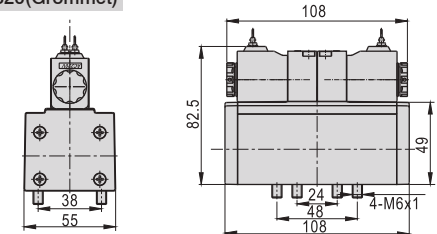

WIVS330C(E/P)(Terminal)

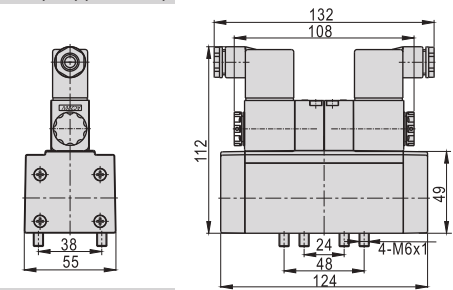

WIVS330C(E/P)(Grommet)

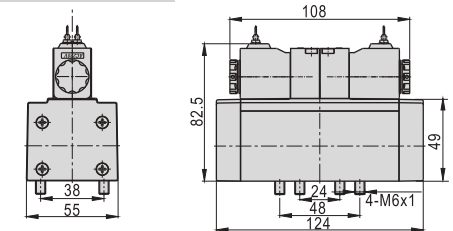

WINMAN ISO VALFLER WIVS SERİLERİ

WIVS301M

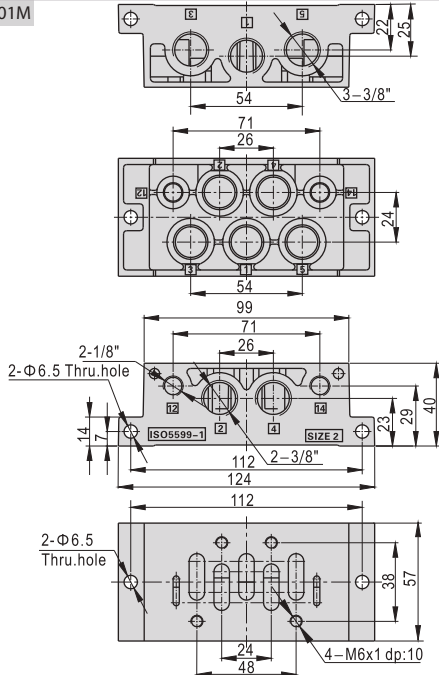

WIVS302M

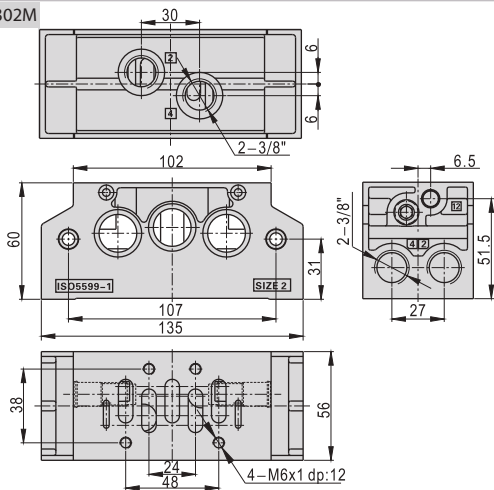

WIVS303M

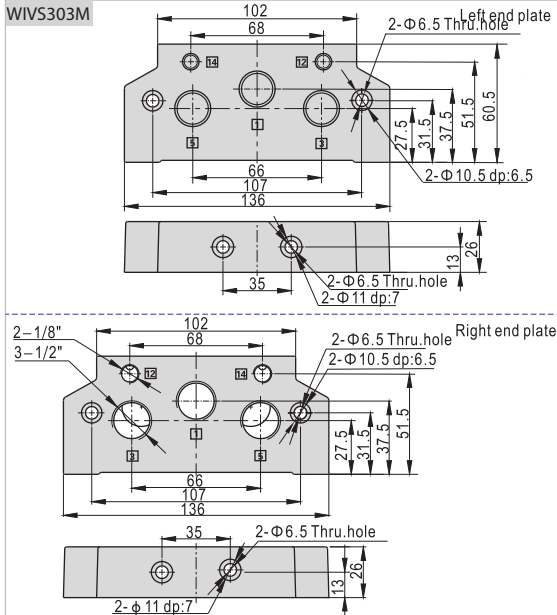

WIVS310+WIVS301M

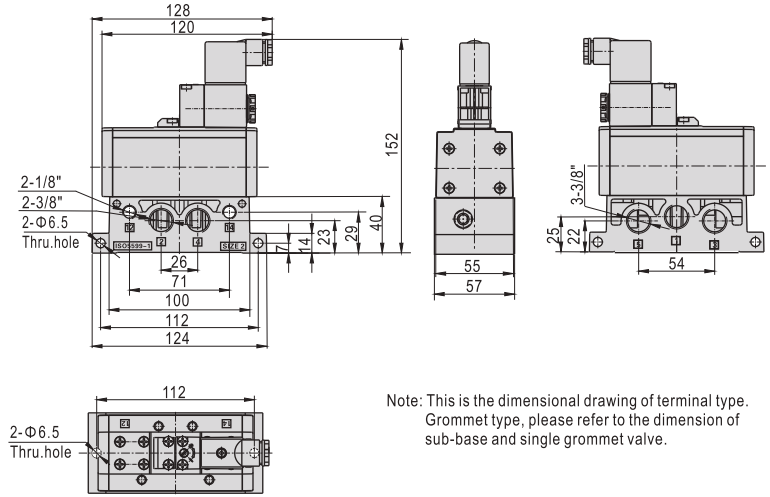

Note: This is the dimensional drawing of terminal type. Grommet type, please refer to the dimension of sub-base and single grommet valve.

WIVS320+WIVS301M

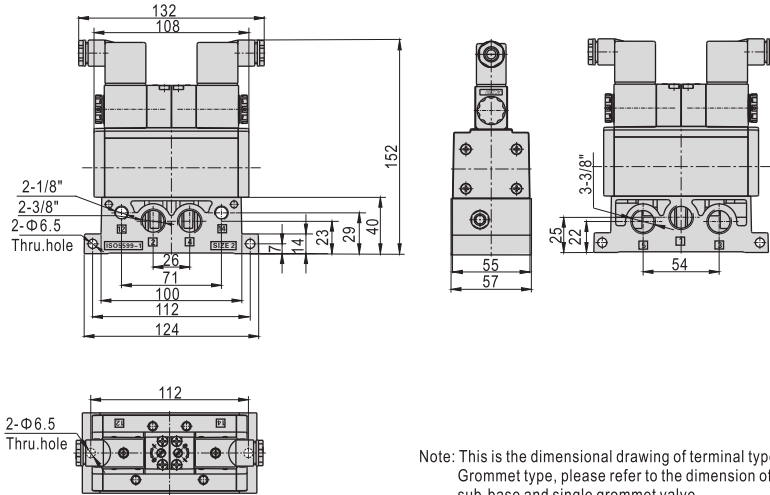

Note: This is the dimensional drawing of terminal type. Grommet type, please refer to the dimension of sub-base and single grommet valve.

WIVS330+WIVS301M

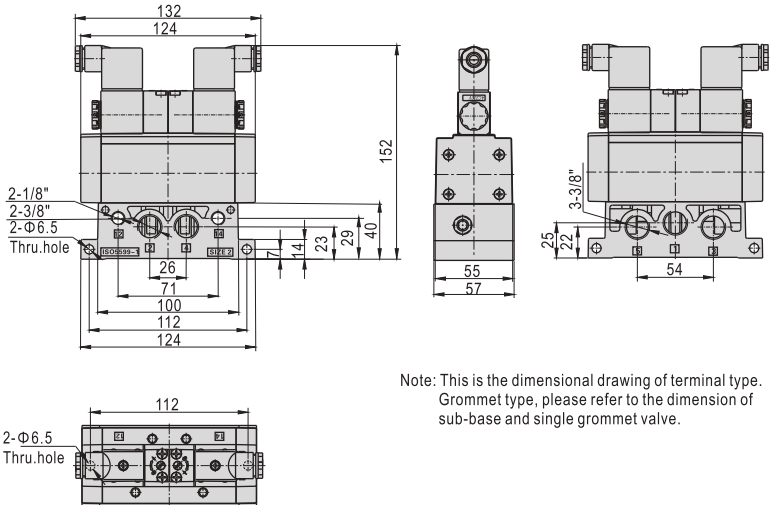

Note: This is the dimensional drawing of terminal type. Grommet type, please refer to the dimension of sub-base and single grommet valve.

WINMAN ISO VALFLER WIVS SERİLERİ

WIVS310+WIVS302M+WIVS303M

Note: n means the number of stations. The dimension of the grommet type (more than 3 stations), please refer to this drawing and the single grommet valve drawing.

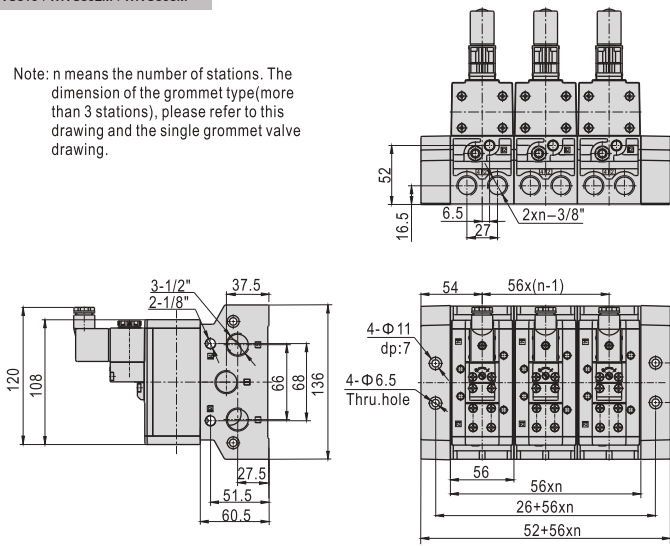

WIVS320+WIVS302M+WIVS303M

Note: n means the number of stations. The dimension of the grommet type (more than 3 stations), please refer to this drawing and the single grommet valve drawing.

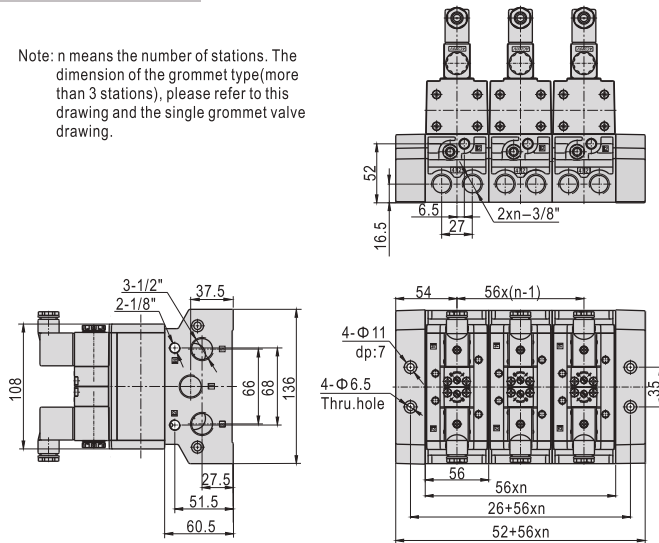

WIVS330+WIVS302M+WIVS303M

Note: n means the number of stations. The dimension of the grommet type (more than 3 stations), please refer to this drawing and the single grommet valve drawing.

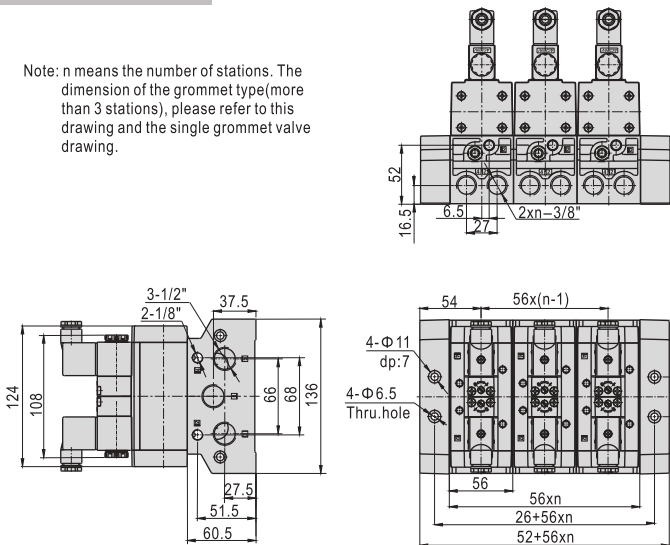

Dimensions (WIVS400 Series)

WIVS410 (Terminal)

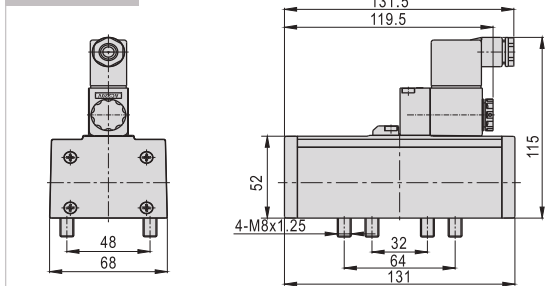

WIVS410 (Grommet)

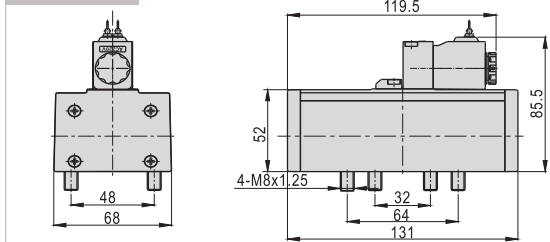

WIVS420 (Terminal)

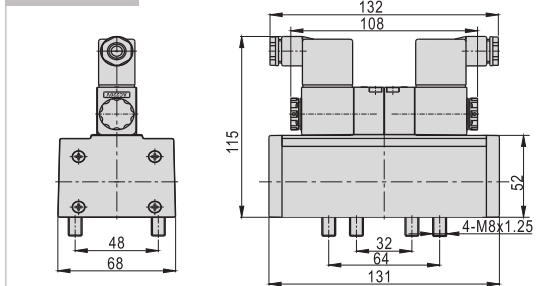

WIVS420 (Grommet)

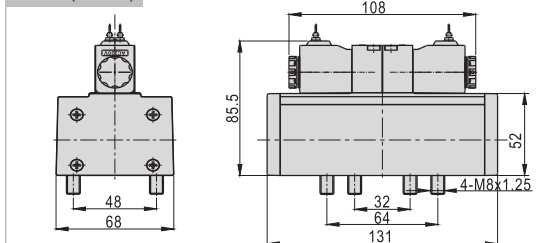

WIVS430C(E/P) (Terminal)

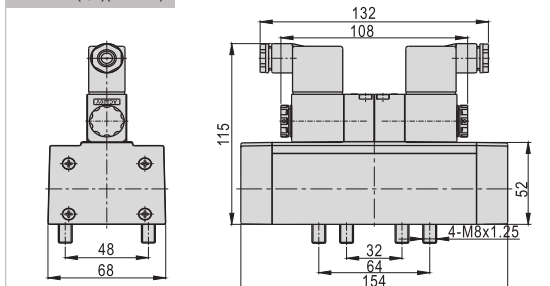

WIVS430C(E/P) (Grommet)

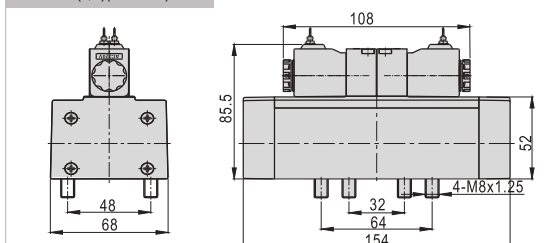

WINMAN ISO VALFLER WIVS SERİLERİ

WIVS401M

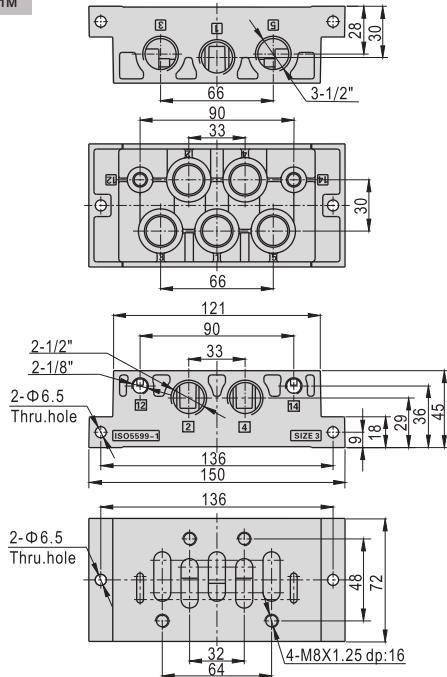

WIVS410+WIVS401M

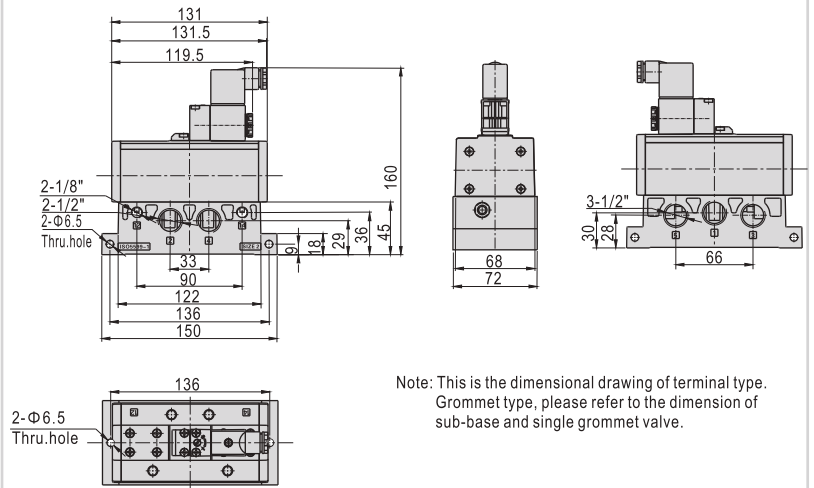

Note: This is the dimensional drawing of terminal type. Grommet type, please refer to the dimension of sub-base and single grommet valve.

WIVS402M

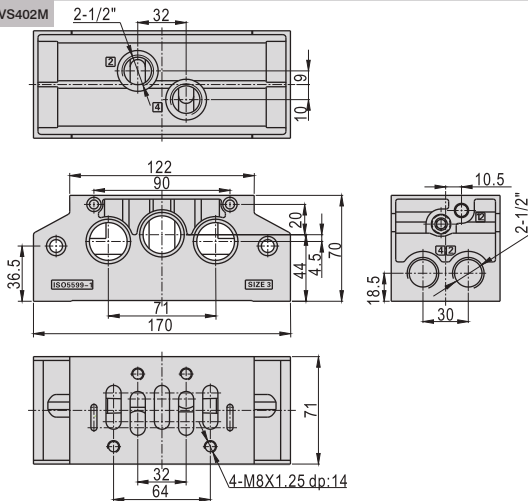

WIVS420+WIVS401M

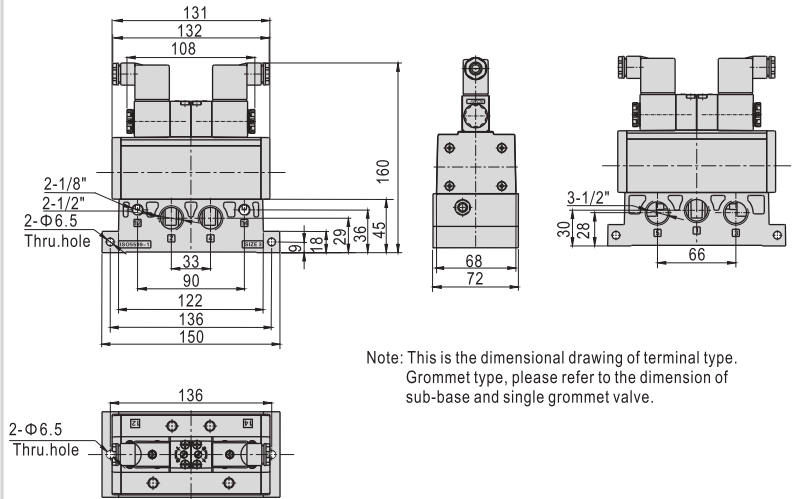

Note: This is the dimensional drawing of terminal type. Grommet type, please refer to the dimension of sub-base and single grommet valve.

WIVS403M

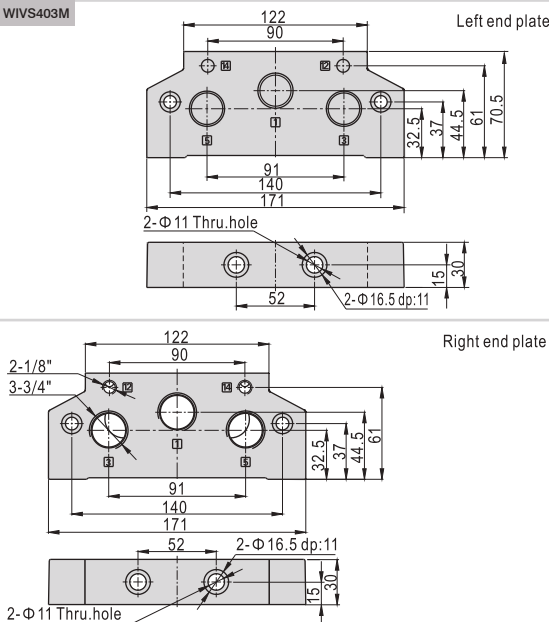

WIVS430+WIVS401M

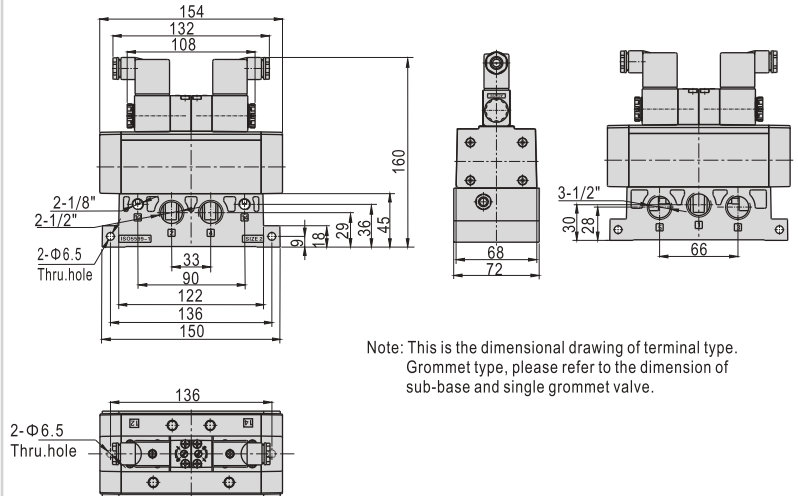

Note: This is the dimensional drawing of terminal type. Grommet type, please refer to the dimension of sub-base and single grommet valve.

WINMAN ISO VALFLER WIVS SERİLERİ

WIVS410+WIVS402M+WIVS403M

Note: n means the number of stations. The dimension of the grommet type (more than 3 stations), please refer to this drawing and the single grommet valve drawing.

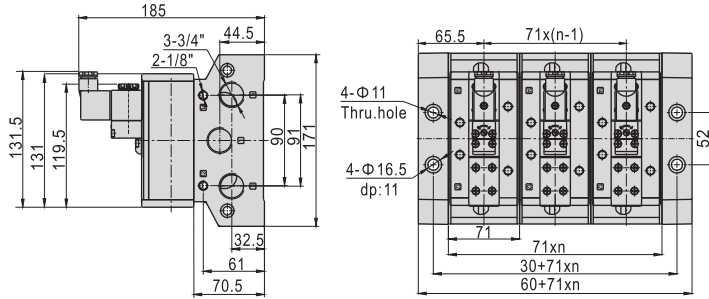

WIVS420+WIVS402M+WIVS403M

Note: n means the number of stations. The dimension of the grommet type (more than 3 stations), please refer to this drawing and the single grommet valve drawing.

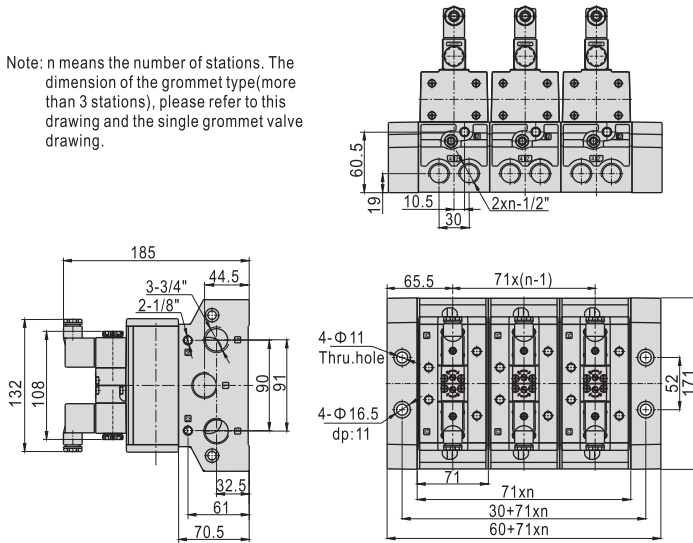

WIVS430+WIVS402M+WIVS403M

Note: n means the number of stations. The dimension of the grommet type (more than 3 stations), please refer to this drawing and the single grommet valve drawing.

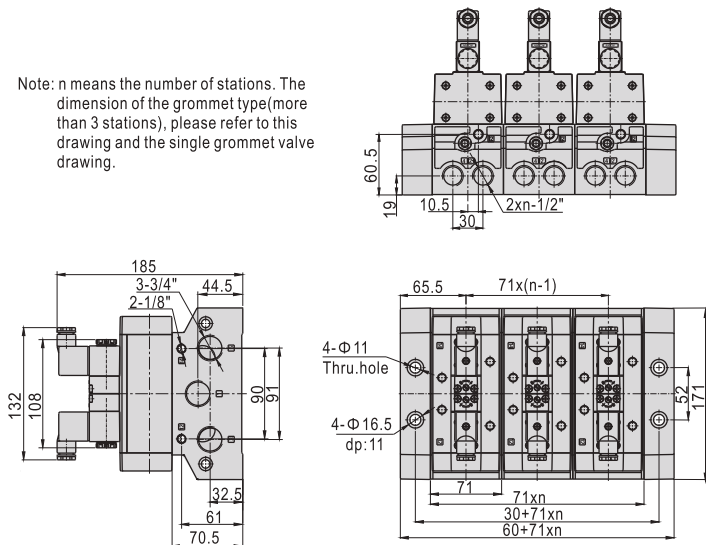

Dimensions (WIVS600 Series)

WIVS610(Terminal)

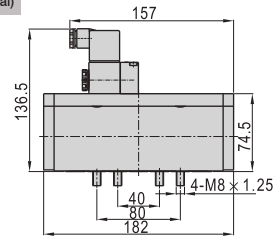

WIVS610(Grommet)

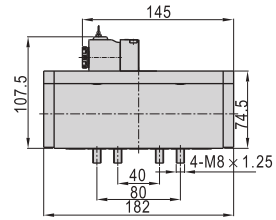

WIVS620/630(Terminal)

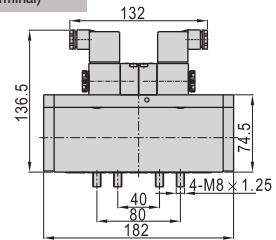

WIVS620/630(Grommet)

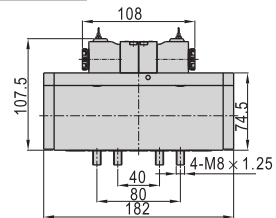

WINMAN ISO VALFLER WIVS SERİLERİ

WIVS601M

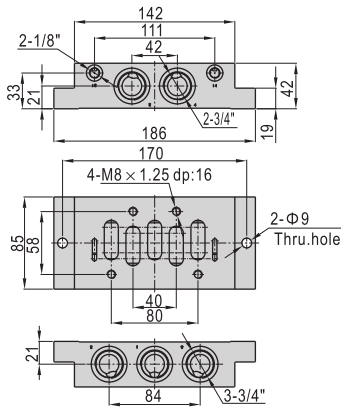

WIVS602M

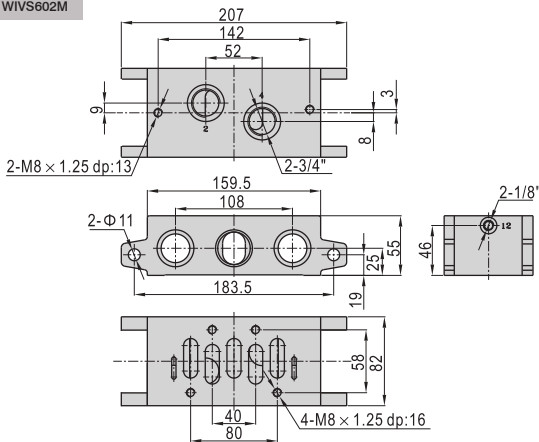

WIVS603M

Left end plate

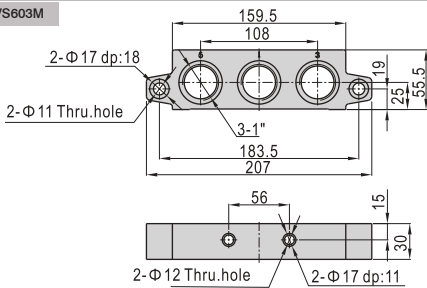

Right end plate

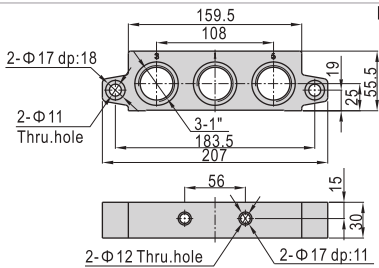

WIVS604M

Left port

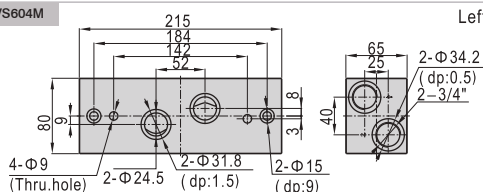

Right port

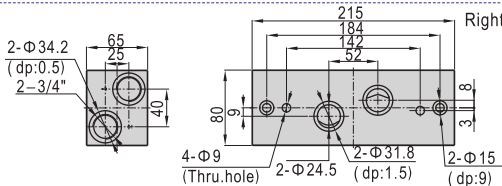

WIVS610+WSIV601M

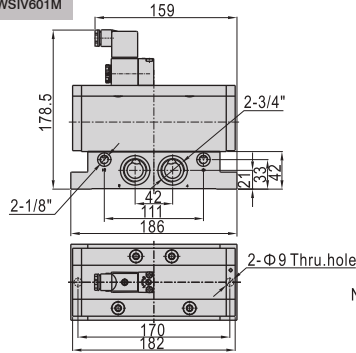

Note: This is the dimensional drawing of terminal type. Grommet type, please refer to the dimension of sub-base and single grommet valve.

WIVS620/630+WIVS601M

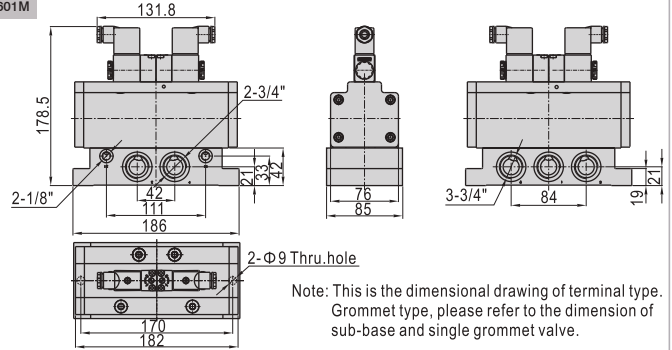

Note: This is the dimensional drawing of terminal type. Grommet type, please refer to the dimension of sub-base and single grommet valve.

WIVS610+WIVS602M+WIVS603M+WIVS604M

Note: This is the dimensional drawing of terminal type. Grommet type, please refer to the dimension of sub-base and single grommet valve.

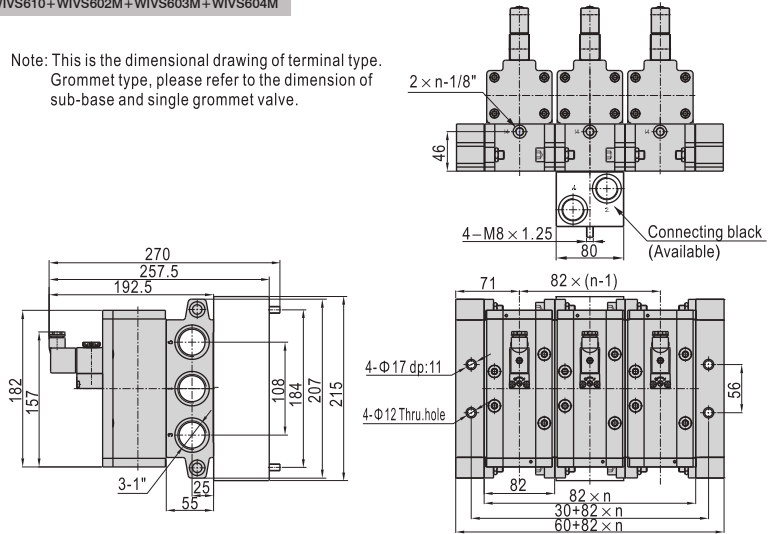

WIVS620/630+WIVS602M+WIVS603M+WIVS604M

Note: This is the dimensional drawing of terminal type. Grommet type, please refer to the dimension of sub-base and single grommet valve.

